



THANK YOU FOR VOTING TEXECOM

INSTALLATION MANUAL

Veritas Excel

Veritas R8Plus

**Security Control Panel with
Communicator Interface**



Texecom
www.texe.com

Table of Contents

Section	Page
1	4
Programming Summary	
1.1	4
1.1.1	5
1.1.2	6
2	7
Installation	
2.1	7
2.1.1	7
2.2	8
2.3	9
2.4	9
2.4.1	10
2.4.2	11
2.4.3	14
2.4.4	14
2.4.5	16
2.4.6	16
2.4.7	16
2.4.8	17
2.5	17
2.6	18
2.7	19
2.7.1	19
2.7.2	19
2.7.3	19
2.7.4	19
2.7.5	19
2.7.6	20
2.7.7	20
2.7.8	20
2.7.9	20
2.7.10	20
2.7.11	20
2.7.12	21
2.7.13	21
3	22
Programming	
3.1	22
3.2	22
3.2.1	22
3.2.2	23
3.2.3	23
3.2.4	24
3.2.5	24
3.2.6	25
3.3	25
3.4	25
3.5	26
3.6	26
3.7	27
3.8	27
3.9	28
3.10	28
3.10.1	28
3.10.2	30

Table of Contents

Section	Page	
3.11	Changing Zone Types when Part Setting	31
3.11.1	Programming which Part Sets will Change Zone Types ②①	32
3.11.2	Programming the Zones that will Change to Entry/Exit ②①	32
3.11.3	Programming the Zones that will Change to Inhibited Entry ②②	32
3.11.4	Programming the Zones that will Change to Guard ②③	32
3.12	Programming the Date and Time	32
3.12.1	Programming the Date ②⑤	33
3.12.2	Programming the Time ②⑥	33
3.13	Programming the Service Timers	33
3.13.1	Programming Service Timer One (Reminder) ②⑦	33
3.13.2	Programming Service Timer Two (Nuisance) ②⑧	34
3.13.3	Programming Service Timer Three (Lockout) ②⑨	34
3.14	Programming the Times ③⑦	34
3.15	The Seven Event Basic Log	35
3.15.1	Clearing the Seven Event Basic Log ④①	35
3.15.2	Displaying the Seven Event Basic Log ④②	35
3.16	Programming the Suites	35
3.16.1	Programming the Full Set Suite ⑤①	35
3.16.2	Programming the Part Set Suites ⑤②	36
3.16.3	Programming the Chime Suite ⑤⑤	36
3.16.4	Programming the Cleaner Suite ⑤⑥	36
3.16.5	Programming the Double Knock Suite ⑤⑦	36
3.16.6	Programming the Manual Omit Suite ⑤⑧	37
3.16.7	Programming the Zone Invert Suite ⑤⑨	37
3.16.8	Programming the Zone Disable Suite ④⑧	37
3.16.9	Programming the Zone Soak Test Suite ④⑨	37
3.17	Assigning Access Codes	38
3.17.1	User Number	38
3.17.2	Access Code	38
3.17.3	Access Level	39
3.17.4	Access Type	40
3.18	Programming Access Codes	40
3.18.1	Changing Your Own Access Code ⑥①	40
3.18.2	Assigning a New Access Code ⑥① – ⑥⑧	41
3.18.3	Displaying Your User Number ⑥⑨	41
3.18.4	Changing Access Levels ⑦① – ⑦⑧	42
3.18.5	Displaying Your Access Level ⑦⑨	42
3.19	Programming the Communicator Interface	43
3.19.1	Programming the Communicator Interface Selections ⑧①	43
3.19.2	Testing the Communicator Interface ⑧②	43
4	Technical Specification	44
4.1	Power Supply	44
4.2	Physical	44
4.3	Environmental	44
4.4	Electrical	44
4.5	Fuses	45
4.6	Miscellaneous	45
4.7	Safety Notes	45
4.8	European Standards	46
4.8.1	EN 50131	46
4.9	Warranty	47
5	Installation Records	48
5.1	Installation Details	48
5.2	Maintenance & Call-Out Record	48
5.3	Access Code Table	49
5.4	Notes	50
5.5	Registered Installer Application Form	51

1 Programming Summary

1.1 Programming Menu

Programming Option	Option Code	Programming Procedure	Factory Setting
Miscellaneous Selections Zero	0 0	Select/De-select Option Number(s) (1) to (8) Press (PROG.)	
Miscellaneous Selections One	0 1	Select/De-select Option Number(s) (1) to (8) Press (PROG.)	
Miscellaneous Selections Two	0 2	Select/De-select Option Number(s) (1) to (8) Press (PROG.)	
Miscellaneous Selections Three	0 3	Select/De-select Option Number(s) (1) to (8) Press (PROG.)	
Number of Alarm Activations	0 4	Enter Number of Alarm Activations (?) (?) Press (PROG.)	03
Test Sounders, Strobe, SW+	0 5	Press (5) (4) (3) (2) (1) in turn Press (RESET)	
Walk Test (Non-Latching)	0 6	Conduct Walk Test Press (RESET)	
Re-Load Factory Settings	0 7	Press (PROG.)	
Switched Positive Output	0 8	Select Function (1) to (8) Press (PROG.)	Set + Ve with Reset (6)
Configure Remote Keypads	0 9	View Display Press (PROG.)	
Detector Programmable Features	1 0	Select Feature Set (0) to (9) Press (PROG.)	None (0)
Zone 1 Zone Type	1 1	Select Zone Type (1) to (8) Press (PROG.)	Entry/Exit (6)
Zone 2 Zone Type	1 2	Select Zone Type (1) to (8) Press (PROG.)	Inhibited Entry (2)
Zone 3 Zone Type	1 3	Select Zone Type (1) to (8) Press (PROG.)	Guard (3)
Zone 4 Zone Type	1 4	Select Zone Type (1) to (8) Press (PROG.)	Guard (3)
Zone 5 Zone Type	1 5	Select Zone Type (1) to (8) Press (PROG.)	Guard (3)
Zone 6 Zone Type	1 6	Select Zone Type (1) to (8) Press (PROG.)	Guard (3)
Zone 7 Zone Type	1 7	Select Zone Type (1) to (8) Press (PROG.)	Guard (3)
Zone 8 Zone Type	1 8	Select Zone Type (1) to (8) Press (PROG.)	Guard (3)
Walk Test (Latching)	1 9	Conduct Walk Test Press (RESET)	
Part Sets Which Change Zone Types	2 0	Select Part Set(s) (1) to (4) Press (PROG.)	Parts Sets 1 & 3
Change into Entry/Exit Suite	2 1	Select Zone Number(s) (1) to (8) Press (PROG.)	Zone 2 Included
Change into Inhibited Entry Suite	2 2	Select Zone Number(s) (1) to (8) Press (PROG.)	No Zones Included
Change into Guard Suite	2 3	Select Zone Number(s) (1) to (8) Press (PROG.)	Zone 1 Included
Program Current Date	2 5	Enter Date DD/MM/YY Press (PROG.)	
Program Current Time	2 6	Enter Time HH:MM:SS Press (PROG.)	
Program Service Timer 1 Date	2 7	Enter Date DD/MM/YY Press (PROG.)	
Program Service Timer 2 Date	2 8	Enter Date DD/MM/YY Press (PROG.)	
Program Service Timer 3 Date	2 9	Enter Date DD/MM/YY Press (PROG.)	
Full Set Exit Time (sec)	3 1	Enter Exit Time (?) (?) Press (PROG.)	30 sec
Part Set Exit Time (sec)	3 2	Enter Exit Time (?) (?) Press (PROG.)	30 sec
Full Set Entry Time (sec)	3 3	Enter Entry Time (?) (?) Press (PROG.)	30 sec
Part Set Entry Time (sec)	3 4	Enter Entry Time (?) (?) Press (PROG.)	30 sec
Bell Cut-Off Time (min)	3 5	Enter Cut-Off Time (?) (?) Press (PROG.)	15 min
Error Tone Suspension Time (sec)	3 6	Enter Suspension Time (?) (?) Press (PROG.)	10 sec
Bell Delay Time (min)	3 7	Enter Delay Time (?) (?) Press (PROG.)	00 (Instant Bells)
Second Intruder Time (min)	3 8	Enter Second Intruder Time (?) (?) Press (PROG.)	45 min
Zone Soak Test Time (days)	3 9	Enter Soak Test Time (?) (?) Press (PROG.)	14 days
Clear Seven Event Basic Log	4 0	Press (PROG.)	
Basic Log Event 1 (most recent)	4 1	View Display (Press (OMIT) for Extended Display) Press (RESET)	
Basic Log Event 2	4 2	View Display (Press (OMIT) for Extended Display) Press (RESET)	
Basic Log Event 3	4 3	View Display (Press (OMIT) for Extended Display) Press (RESET)	
Basic Log Event 4	4 4	View Display (Press (OMIT) for Extended Display) Press (RESET)	
Basic Log Event 5	4 5	View Display (Press (OMIT) for Extended Display) Press (RESET)	
Basic Log Event 6	4 6	View Display (Press (OMIT) for Extended Display) Press (RESET)	
Basic Log Event 7 (least recent)	4 7	View Display (Press (OMIT) for Extended Display) Press (RESET)	

Programming Option	Option Code	Programming Procedure	Factory Setting
Zone Disable Suite	(4)(8)	Select Zone Number(s) (1) to (8) Press (PROG.)	No Zones Included
Zone Soak Test Suite	(4)(9)	Select Zone Number(s) (1) to (8) Press (PROG.)	No Zones Included
Full Set Suite	(5)(0)	Select Zone Number(s) (1) to (8) Press (PROG.)	All Zones Included
Part Set Suite 1	(5)(1)	Select Zone Number(s) (1) to (8) Press (PROG.)	Zones 5, 6, 7 Omitted
Part Set Suite 2	(5)(2)	Select Zone Number(s) (1) to (8) Press (PROG.)	Zones 5, 6, 7 Omitted
Part Set Suite 3	(5)(3)	Select Zone Number(s) (1) to (8) Press (PROG.)	Zones 5, 6, 7 Omitted
Part Set Suite 4	(5)(4)	Select Zone Number(s) (1) to (8) Press (PROG.)	Zones 5, 6, 7 Omitted
Chime Suite	(5)(5)	Select Zone Number(s) (1) to (8) Press (PROG.)	No Zones Included
Cleaner Suite	(5)(6)	Select Zone Number(s) (1) to (8) Press (PROG.)	No Zones Included
Double Knock Suite	(5)(7)	Select Zone Number(s) (1) to (8) Press (PROG.)	No Zones Included
Manual Omit Suite	(5)(8)	Select Zone Number(s) (1) to (8) Press (PROG.)	Zone 1 Omitted
Zone Invert Suite	(5)(9)	Select Zone Number(s) (1) to (8) Press (PROG.)	No Zones Included
Program Your Own Code PIN	(6)(0)	Enter New Code PIN (???) Press (PROG.)	
Program Code 1 PIN	(6)(1)	Enter New Code PIN (???) Press (PROG.)	(4)(3)(2)(1)
Program Code 2 PIN	(6)(2)	Enter New Code PIN (???) Press (PROG.)	(1)(2)(3)(4)
Program Code 3 PIN	(6)(3)	Enter New Code PIN (???) Press (PROG.)	
Program Code 4 PIN	(6)(4)	Enter New Code PIN (???) Press (PROG.)	
Program Code 5 PIN	(6)(5)	Enter New Code PIN (???) Press (PROG.)	
Program Code 6 PIN	(6)(6)	Enter New Code PIN (???) Press (PROG.)	
Program Code 7 PIN	(6)(7)	Enter New Code PIN (???) Press (PROG.)	
Program Code 8 PIN	(6)(8)	Enter New Code PIN (???) Press (PROG.)	
Display Your Own User Number	(6)(9)	View Display Press (RESET)	
Display Panel Type	(7)(0)	View Display Press (RESET)	Z1, Z2, Z3 On
Program Code 1 Access Level	(7)(1)	Select Access Level (1) to (8) Press (PROG.)	Master User (5)
Program Code 2 Access Level	(7)(2)	Select Access Level (1) to (8) Press (PROG.)	Boss Engineer (8)
Program Code 3 Access Level	(7)(3)	Select Access Level (1) to (8) Press (PROG.)	Null (7)
Program Code 4 Access Level	(7)(4)	Select Access Level (1) to (8) Press (PROG.)	Null (7)
Program Code 5 Access Level	(7)(5)	Select Access Level (1) to (8) Press (PROG.)	Null (7)
Program Code 6 Access Level	(7)(6)	Select Access Level (1) to (8) Press (PROG.)	Null (7)
Program Code 7 Access Level	(7)(7)	Select Access Level (1) to (8) Press (PROG.)	Null (7)
Program Code 8 Access Level	(7)(8)	Select Access Level (1) to (8) Press (PROG.)	Null (7)
Display Your Own Access Level	(7)(9)	View Display Press (RESET)	
Communicator Interface Selections	(8)(0)	Select/De-select Option Number(s) (1) to (8) Press (PROG.)	
Test Communicator Interface	(8)(1)	Toggle Channel(s) (1) to (8) Press (RESET)	

1.1.1 Programming Reference Table

No.	Test Outputs (0)(5)	SW+ Function (0)(8)	Detector Programmable Features (1)(0)	Zone Type (1)(?)	Extended Display	Code Type (7)(?)	Communicator Channels	No.
0	All Off		0 Pulses					0
1	Bell	Set +Ve	4 Pulses	PTS	Bell & Global Tamper	User	Fire	1
2	Strobe	Alarm +Ve & Reset	5 Pulses	Inhibited Entry	Power	Engineer	PA	2
3	Sounder Lo	Reset	6 Pulses	Guard	Lid Tamper (inc. RKP)	PA	Intruder	3
4	Sounder Hi	Tamper	7 Pulses	Fire	Line Monitor	Duress	Set	4
5	SW+	Mains Fail	8 Pulses	Tamper	RKP Off-line	Master	Abort	5
6	Hold-Off	Set +Ve & Reset	9 Pulses	Entry/Exit	Code PIN Tamper	Cleaner	Part	6
7		Walk Test	10 Pulses	PA	PA (Keypad or Code)	Null	Duress	7
8		Entry/Exit	11 Pulses	Keyswitch	EOL Tamper	Boss	2 nd Intruder	8
9			12 Pulses					9

1.1.2 Factory Settings

Option	Miscellaneous Selections Zero ①①	Factory Setting
1	Cancel Strobe with Bell	Off
2	Keypad PA (pressing ③ and ⑨ together causes PA alarm)	On
3	Single Button Setting	On
4	Silent Part Set Confirmation Tone	Off
5	EN 50131-1 Requirements	Off
6	Time Limit Engineer Access	Off
7	Reset Button Cancels Setting	On
8	Old Style <i>Veritas</i> Sounds (must be selected for older version remote keypads)	Off

Option	Miscellaneous Selections One ①①	Factory Setting
1	Internal Sounders Only on Unset Tamper Alarm	On
2	Internal Sounders Only on Part Set Zone Alarm	On
3	Internal Sounders Only on Part Set Tamper Alarm	On
4	Silent Part Set (no exit tone on part set)	Off
5	High Level Chime (chime at full volume)	Off
6	Invert Bell Output (negative removed instead of negative applied, useful for SCBs)	Off
7	Final Door Set (system sets 3 seconds after final door closure)	Off
8	Unlock Engineer Code (re-loading factory settings restores default Engineer code)	On

Option	Miscellaneous Selections Two ①②	Factory Setting
1	Engineer Reset on Any Alarm (see section 3.2.5, page 24)	Off
2	Engineer Reset on Tamper Alarm (see section 3.2.5, page 24)	Off
3	Disable User Ability to Omit Tamper	Off
4	Code PIN Tamper (tamper alarm after 16 invalid key presses when unset)	Off
5	Random Number Remote Reset (RNRR, see section 3.2.5, page 24)	Off
6	Push To Set (see section 3.2.6, page 25)	Off
7	Strobe Flash on Full Set (see section 3.2.3, page 23)	On
8	Invert Switched Positive Output (off = negative removed, on = negative applied)	Off

Option	Miscellaneous Selections Three ①③	Factory Setting
1	Mains Frequency (off = 50Hz, on = 60Hz)	Off
2	EOL Tamper Alarm on Zone Short Circuit (S/C)	Off
3	EOL Tamper Alarm on Zone Open Circuit (O/C)	Off
4	Engineer Reset on Power Up (see section 3.2.5, page 24)	Off
5	Reserved for Future Use	Off
6	Reserved for Future Use	Off
7	Automatically Omit Zone on Alarm	Off
8	Automatically Omit Keyswitch Zone when EOL Tampered	Off

Option	Communicator Selections ⑧①	Factory Setting
1	Communicator Outputs Latch until System is Reset	On
2	Line Monitor Input causes Tamper Alarm on Line Cut	Off
3	Invert Communicator Outputs (off = active low, on = active high)	Off
4	Invert Remote Reset Input (off = active if negative removed, on = active if negative applied)	Off
5	Remote Reset Input Silences Internal Sounder during Alarm	Off
6	Remote Reset Input Clears Engineer Reset (section 3.2.5, page 24)	Off
7	Silent PA	Off
8	Enable 90 Second Abort Time Limit	On

2 Installation

2.1 Introduction to the Control Panel

The control panel is designed to maximise user friendliness for both the installer and the user. Programming is usually unnecessary as the **factory settings (section 1.1.2, page 6)** have been carefully selected to suit most installations without alteration. However all functions are fully programmable for **Complete Control**. All programming is stored in a Non Volatile Memory (NVM) and thus all information is retained even in the event of a complete loss of power.

2.1.1 Introduction to End Of Line Technology

Those already familiar with End of Line (EOL) Technology (sometimes referred to as Balanced Zones) may wish to skip this section.

So called Normally Closed Loops have only two possible states, that is either open (zone in fault) or closed (zone clear). It is therefore necessary to have separate 24 hour tamper loop(s) to protect the zones when the system is unset and they are not being monitored.

End of Line Resistance is a technique which, by adding resistance at the last detector in the loop, provides each loop with its own 24 hour tamper protection.

The panel can distinguish up to four possible states; low resistance (10kΩ) is interpreted as zone clear, high resistance (33kΩ) is interpreted as zone in fault. Short circuit may optionally be interpreted as tampering or zone clear. Open circuit may optionally be interpreted as tampering or zone in fault. Thus there are four possible configurations depending on the options selected. These include normally closed operation (a Global System Tamper zone is provided) and become progressively more secure, as follows:

Figure 1 - EOL Wiring

Miscellaneous Option 3.2 (S/C = Tamper)	Off
Miscellaneous Option 3.3 (O/C = Tamper)	Off

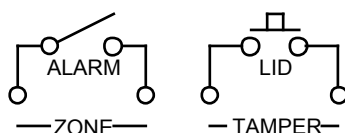

Figure 1a - Normally Closed Operation

Miscellaneous Option 3.2 (S/C = Tamper)	On
Miscellaneous Option 3.3 (O/C = Tamper)	Off

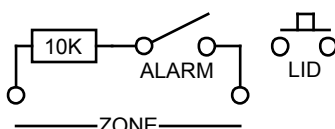

Figure 1b - "American" Operation

Miscellaneous Option 3.2 (S/C = Tamper)	Off
Miscellaneous Option 3.3 (O/C = Tamper)	On

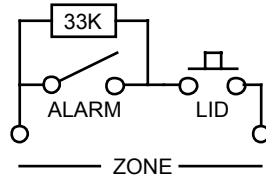

Figure 1c - "European" Operation (one detector per zone)

Miscellaneous Option 3.2 (S/C = Tamper)	On
Miscellaneous Option 3.3 (O/C = Tamper)	On

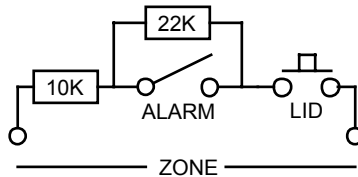

Figure 1d - High Security Operation (one detector per zone)

Resistors are coded with coloured bands to identify the different values, as follows:

Resistor Colour Code	
10kΩ	Brown, Black, Orange, Brown
22kΩ	Red, Red, Orange, Brown
33kΩ	Orange, Orange, Orange, Brown



- 1) The control panel is supplied with links fitted across the eight zones (Z1 - Z8), the Global System Tamper (TAMP) and Bell Tamper (SAB C, D) to simulate closed circuits:
 - a) These links are removed during installation as each zone is connected.
 - b) The Global System Tamper zone will typically only be used with normally closed operation.
 - c) If a zone is not required then the link should be left in place.
 - d) If EOL operation is selected and a zone is not required then the zone link should be replaced with a 10K resistor (supplied).
- 2) When wiring a 24 Hour zone (Fire, PA and Tamper), such as a panic button, it may be more convenient to fit the EOL resistor(s) in the panel than in the detector.

2.2 Testing the Control Panel (Pre-Installation)

Use the following procedure to test the control panel before installation:

- Remove the screw covers by inserting a screwdriver into the screw cover slot and turning anti-clockwise whilst applying pressure outwards.
- Unscrew the lid screws and remove the lid. Connect the remote keypad as described in the RKP instructions.
- Connect the black battery-lead to the negative (-) terminal of the standby battery and the red battery-lead to the positive (+) terminal of the standby battery. All the indicator lights will come on. After 10 seconds the zone lights will turn off and a repeating 9 bleep error tone will start.
- **Enter the factory-set User code 4321.** The error tone will stop. The Power light will be flashing.
- **Enter the factory-set Engineer code 1234 and press (PROG).** All the zone lights will illuminate.
- **Enter 06.** The zone lights will turn off. The control panel will sound a repeating 9 bleep error tone and the Tamper light will be on.
- Remove and replace each zone link in turn. When the link is removed check that the corresponding zone light comes on.
- Finally press the panel (and RKP) lid tamper springs. Check the Tamper light goes out and the panel sounds the quiet exit tone.
- After testing all the zones and tamper disconnect the battery.



If the battery is flat or faulty the RKP may not accept key presses.

2.3 Mounting the Control Panel

Mount the control panel on a flat, plumb wall using at least three appropriate screws. The rear casing has been designed with a central key-hole slot so that mounting is possible without removing the Printed Circuit Board (PCB). The angled slot in the lower corner has been provided to allow the panel to be levelled easily. If the PCB has to be removed, carefully pull back the two front PCB securing clips, lift the front of the PCB and slide it downward. To replace the PCB simply reverse the above procedure.

- 1) It is essential to ensure that none of the fixing slots or cable entries are accessible after fixing.
- 2) Mains cabling must be secured (e.g. with a cable tie) to one of the anchor points provided.



2.4 Wiring the Control Panel

WARNING: ELECTRICITY CAN KILL
BEFORE connecting the control panel
ALWAYS disconnect the supply at the consumer unit.
If in ANY doubt consult a qualified electrician.



- 1) ONLY connect the mains supply to the mains terminal block, NEVER connect the mains supply directly to the PCB.
- 2) ALWAYS refer to National Wiring Regulations when conducting installation.
- 3) An appropriate and readily accessible disconnection device (e.g. an unswitched fused spur) MUST be provided as part of the installation.
- 4) The disconnection device must NOT be fitted in a flexible cord.
- 5) Where identification of the neutral in the mains supply is NOT possible a two-pole disconnection device MUST be used.
- 6) The building mains supply MUST incorporate appropriate short-circuit backup protection (e.g. a fuse or circuit breaker) of High Breaking Capacity (HBC, at least 1500A).
- 7) Use mains cable of adequate carrying capacity for the rated current (i.e. at least 0.75mm²).



- 1) Although the Control Panel has been designed for maximum compatibility, for optimum performance, it is highly recommended that the Control Panel should be used with Texecom's range of detectors, sounders and batteries.
- 2) The control panel is supplied with links fitted across the eight zones (Z1 - Z8), the Global System Tamper (TAMP) and Bell Tamper (SAB C, D) to simulate closed circuits:
 - a) These links are removed during installation as each zone is connected.
 - b) The Global System Tamper zone will typically only be used with normally closed operation.
 - c) If a zone is not required then the link should be left in place.
 - d) If EOL operation is selected and a zone is not required then the zone link should be replaced with a 10K resistor (supplied).
- 3) Older fridges & freezers can be a source of interference as their motor suppression components age. Avoid connecting the panel to the same ring or spur as a fridge or freezer.

2.4.1 Control Panel PCB Layout

Figure 2 - Control Panel PCB Layout

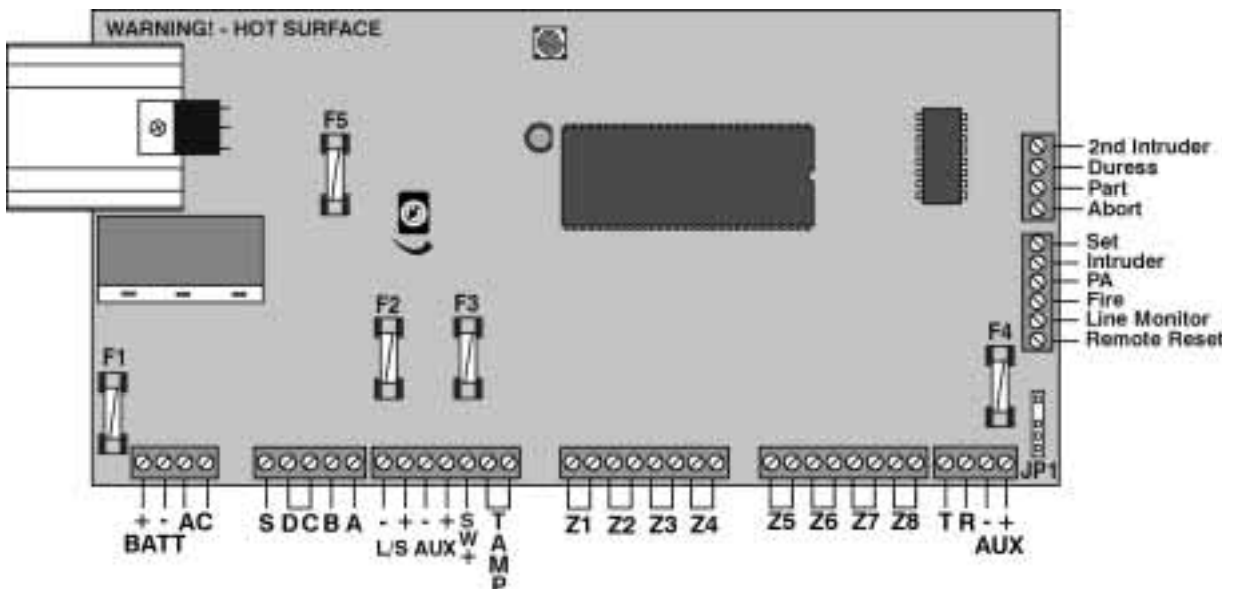

2.4.1.1 PCB Terminals and Fuses

Terminal	Description	Note
AC (2)	Transformer AC in	NOT for mains supply
BATT-	Standby Battery negative	
BATT+	Standby Battery positive	
S	SAB Strobe switched negative	
D	SAB negative Supply	
C	SAB negative Tamper return	
B	SAB Bell switched negative	
A	SAB positive Supply	
L/S (2)	Loudspeaker	
AUX-	Auxiliary Supply negative	use for detectors
AUX+	Auxiliary Supply positive	use for detectors
SW+	Switched Positive output	

Terminal	Description	Note
TAMP	Negative Tamper loop	
Z1 - Z8	Zone loops	
T	Keypad data	
R	Keypad data	
AUX-	Auxiliary Supply negative	use for RKP(s)
AUX+	Auxiliary Supply positive	use for RKP(s)
1 - 8	Channel outputs	
L/M	Line Monitor input	
R/R	Remote Reset input	



- 1) A spare mains fuse is supplied in a clip adjacent to the mains terminal block.
- 2) Spare PCB fuses are supplied in a press-seal bag.

Fuse	Description	Rating
F1	Battery fuse	F1A, 250V, 20mm
F2	Bell & Strobe fuse	F1A, 250V, 20mm
F3	L/S & Detector Auxiliary fuse	F500mA, 250V, 20mm
F4	RKP Auxiliary fuse	F500mA, 250V, 20mm
F5	Power Supply Output fuse	F1.6A, 250V, 20mm



- 1) When replacing a fuse always observe the specified rating and type - failure to do so is dangerous and will invalidate the warranty. Fuses should comply with IEC 127.
- 2) The press-seal bag must NOT be stored inside the panel.

2.4.2 Wiring the External Sounder and Strobe

Always consult the manufacturer's connection instructions. The external sounder and strobe are connected to the five terminals labelled SAB on the control panel as follows:

Terminal	Description
A	Permanent Positive Supply (+12V)
B	Switched Negative to Activate Sounder
C	Negative Tamper Return
D	Permanent Negative Supply (0V)
S	Switched Negative to Activate Strobe

Figure 3 - Typical SAB Connections

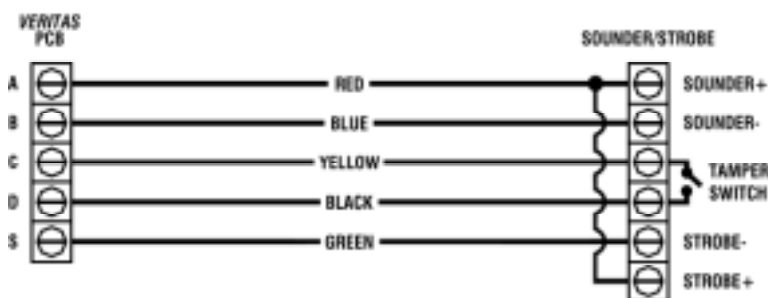



- 1) An external sounder is often referred to as a 'bell' or 'bell-box' even when it is actually an electronic siren.
- 2) The control panel is supplied with a link fitted across the Bell Tamper to simulate a closed circuit. This link would usually be removed during installation.
- 3) If the strobe is a separate unit take the strobe positive supply from 'A' as well.
- 4) A self-activating bell/sounder (SAB) has a built-in battery. After connecting this battery the sounder will usually sound until its cover is fitted and it is supplied with power from the control panel.
- 5) Terminal B may be programmed as switched negative removed rather than switched negative applied to activate sounder (section 3.2.2, page 23). This is useful for SCBs where B would then be used to provide the permanent negative supply.

2.4.2.1 Popular SAB Wiring Diagrams

The following diagrams illustrate how to connect the control panel to the most popular makes of SAB:

Figure 4 - Common SAB Connections

Figure 4a - *Texecom Azura 360/ Tempest/Odyssey Series*

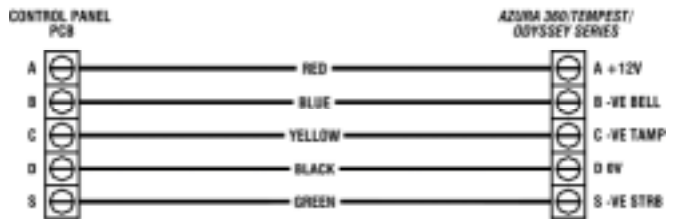

Figure 4b - MAS Modular 3

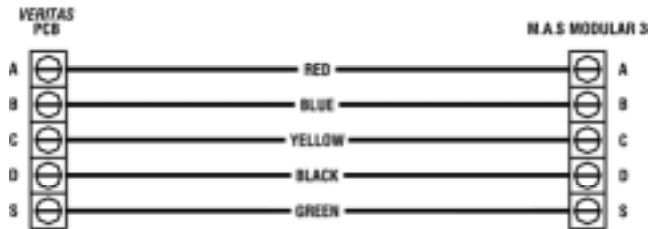

Figure 4c - Citadel Defender

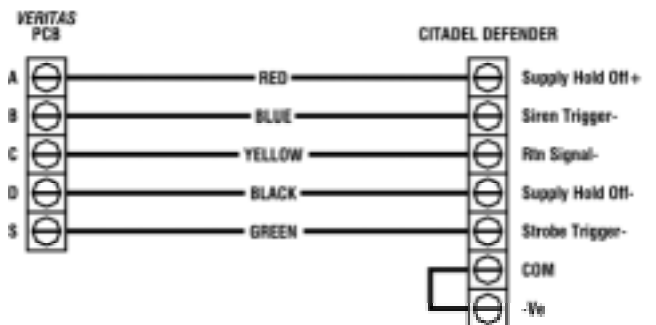

Figure 4d - Volumatic Flashguard

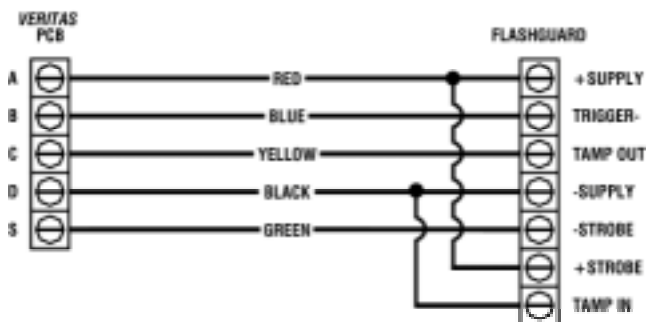

Figure 4e – Gardiner Technology Novagard 2

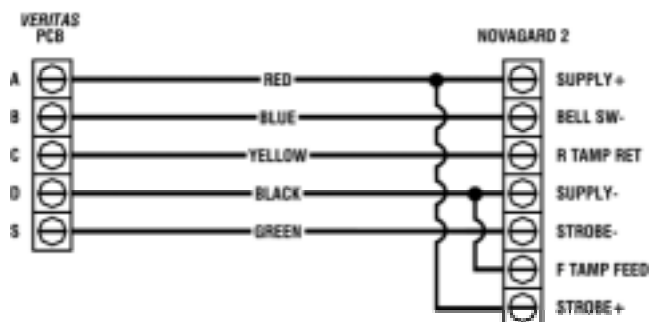

Figure 4f - Activeguard AU101

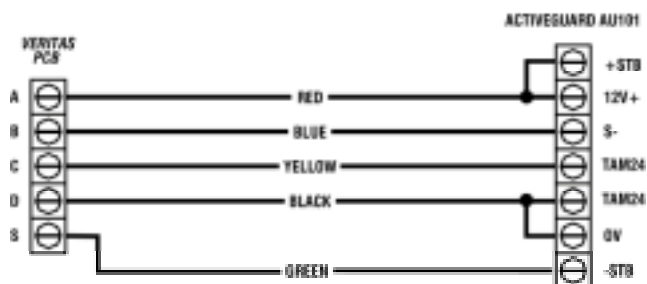
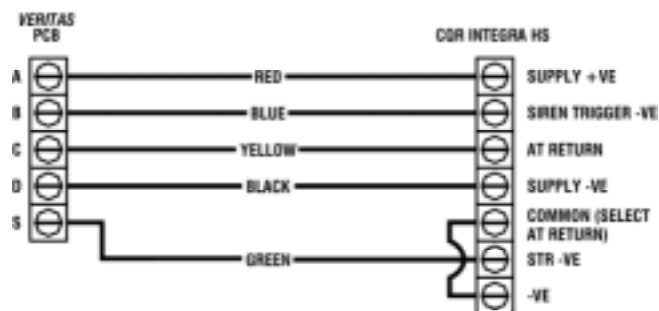

Figure 4g - CQR Integra HS



2.4.3 Magnetic Contacts and Panic Buttons

These are connected to one of the eight terminal pairs labelled Z1 to Z8 on the control panel.

Figure 5 - Wiring Magnetic Contacts

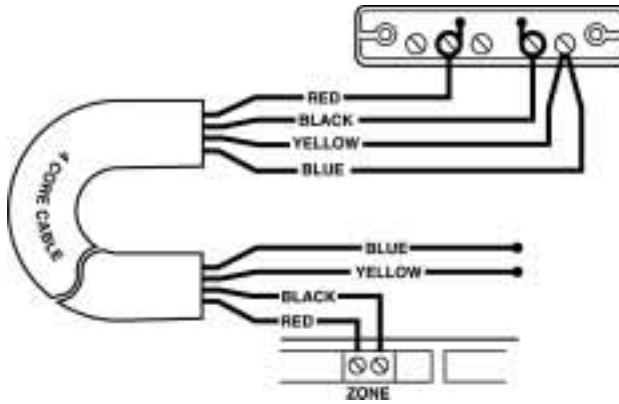

Figure 5a - Wiring a Single Magnetic Contact to a Zone (see also Figure 7)

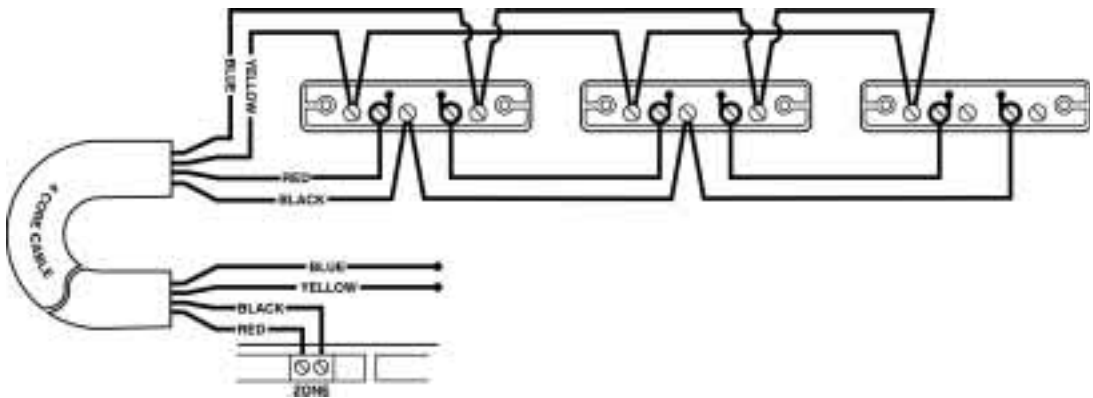

Figure 5b - Wiring Multiple Magnetic Contacts to a Zone (see also Figure 7)



Mixing powered detectors and magnetic contacts on one zone is easiest if the wiring is taken from the control panel to the powered detectors first.

2.4.4 Powered Detectors

Always consult the manufacturer's connection instructions. Powered detectors are connected to one of the eight terminal pairs labelled Z1 to Z8 on the control panel and are powered from the two terminals labelled AUX on the control panel as follows:

Terminal	Connect To	Suggested Colour
AUX+	Detector Positive Supply (+12V)	White
AUX-	Detector Negative Supply (0V)	Green

Figure 6 - Wiring Powered Detectors

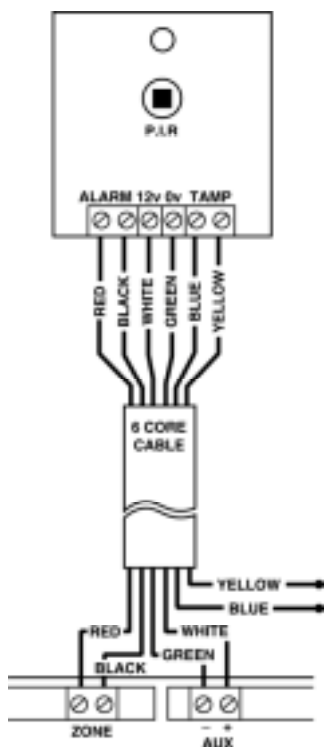

Figure 6a - Wiring a Single Powered Detector to a Zone
(see also Figure 7)

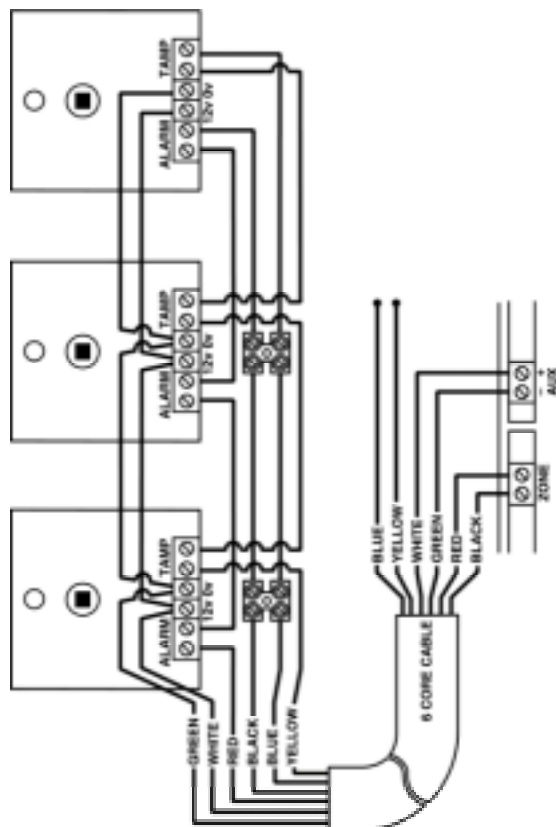

Figure 6b - Wiring Multiple Powered Detectors to a Zone
(see also Figure 7)



- 1) Power is wired in parallel, whereas normally closed alarm loops are wired in series, (normally open alarm loops are wired in parallel).
- 2) Mixing powered detectors and magnetic contacts on one zone is easiest if the wiring is taken from the control panel to the powered detectors first.
- 3) BS 4737 requires that if two or more powered detectors are connected to one zone, they must each have an audible or visual latching indication or both, except on an entry/exit route.

2.4.5 Extension Speaker(s)

These are connected to the two terminals on the control panel labelled L/S.



- 1) The total load including the built-in speaker must not be less than 4Ω (e.g. 2 x 8Ω speakers in parallel, 4 x 16Ω speakers in parallel, 2 x 2Ω speakers in series, 4 x 1Ω speakers in series, etc.)
- 2) The polarity of extension speakers is usually unimportant. However the polarity of the L/S terminals is indicated with + and - markings.

2.4.6 Internal Siren(s)

If required these are connected to two of the external sounder connections, in addition to the external sounder, as follows:

Terminal	Connect To
A	Siren Positive Supply (+12V)
B	Siren Negative Activate/Negative Supply (0V)

2.4.7 Global System Tamper

This is connected to the terminal pair labelled TAMP on the control panel. All the individual zone tamper loops should be wired in series.

Figure 7 - Wiring the Global System Tamper

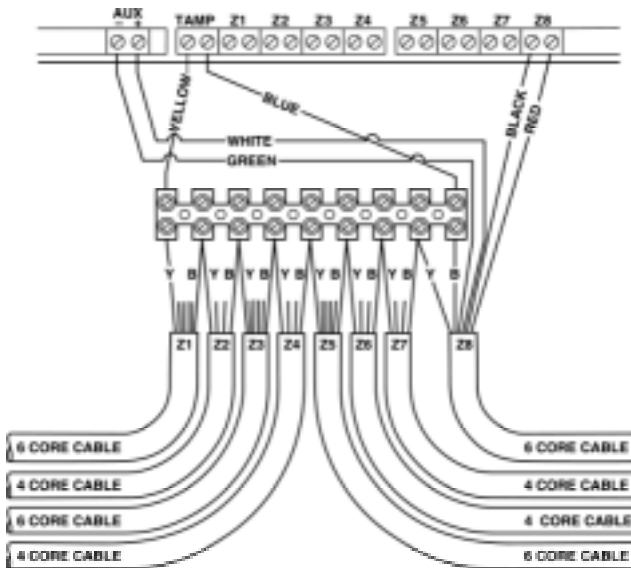

The control panel is supplied with a link fitted across the Global System Tamper to simulate a closed circuit. This link would usually be removed during installation. However the Global System Tamper will typically only be used with normally closed operation, with EOL operation the tamper link would usually be left in place.

2.4.8 Communicator Interface

The Control Panel features an eight output channel digital communicator interface with Line Monitor (L/M) and Remote Reset (R/R) inputs. The polarity of the outputs and the R/R input is programmable (section 3.19.1, page 43). The eight channels are allocated as follows:

Terminal	Description
Channel 1	Fire
Channel 2	PA
Channel 3	Intruder
Channel 4	Set/Unset
Channel 5	Abort
Channel 6	Part Set
Channel 7	Duress
Channel 8	Second Intruder (Sequentially Confirmed Alarm)



- 1) The L/M input should be connected to 0V (AUX-) if not required, otherwise Bell Delay will not operate.
- 2) Second Intruder satisfies the requirements of NACP 14, Issue 1, Section 2.4.

2.5 Commissioning the System (Initial Power Up)

ALWAYS Ensure the mains is off BEFORE removing the front cover

- Connect the black battery lead to the negative (-) terminal of the standby battery and the red battery lead to the positive (+) terminal of the standby battery. All the indicator lights will come on. After 10 seconds the zone lights will turn off and a repeating 9 bleep error tone will start.
- **Enter the factory set User code ④③②①.** The error tone will stop.
- **Enter the factory set Engineer code ①②③④ and press (PROG.)** to access the Programming Menu and disable 24 Hour zones (Fire, PA and Tamper) via the Engineer code. All the zone lights will illuminate.
- Perform a Walk Test as described in section 3.5, page 26. Remember that some powered detectors (e.g. PIRs and Combined Technology Detectors) take several minutes to warm up and become operational.
- Test the internal sounder, external sounder and strobe as described in section 3.4, page 25. To adjust the low-level volume use the control 'pot' on the PCB (see section 2.4.1, page 10), loudness increases anti-clockwise. If the system fails to operate as expected check that the mounting and wiring are as per the instructions.
- Correct any mistakes and repeat the test (see section 2.7, page 19 on Trouble Shooting).
- Replace the lid and secure with the two lid screws supplied - **do not over-tighten.**
- Replace the screw covers.
- **Press (RESET)** to leave the Programming Menu. All the zone lights will turn off.
- The Power light will be flashing to indicate that action is required. Switch on the mains supply to the control panel. The Power light will stop flashing and stay on continuously. If the factory settings (section 1.1.2, page 6) are not appropriate then re-program the system as described in section 3, page 22.
- If you have a meter:
 - Disconnect the battery & check the total non-alarm current is less than 1A.
 - Reconnect the battery & check the total alarm current is not more than 1A.
- The total current is measured as follows:
 - Set your meter to DC current.
 - Connect your meter across F5 (power supply fuse).
 - Remove F5.
 - Record the current drain.
 - Replace F5.
 - Remove your meter.



To avoid accidentally powering down the system be sure to follow **all** the above steps **in order**.

Installation is now complete and the system is ready for use.



- 1) If the battery is flat or faulty the RKP may not accept key presses.
- 2) When the system is full set, after the exit period, the external strobe will flash for approximately 6 seconds (this option can be de-selected, section 3.2.3, page 23).

2.6 Servicing the System

ALWAYS Ensure the mains is off BEFORE removing the front cover



- 1) The Power light on the control panel is a status indicator for the battery charging circuit, a steady light meaning normal. A flashing light means action required - **mains power can still be present**. ALWAYS use a suitable mains test instrument to confirm that mains power is no longer present.
- 2) The transformer and heatsink may be hot during and after use - do NOT touch.

- Test the internal sounder, external sounder and strobe as described in section 3.4, page 25. Perform a Walk Test as described in section 3.5, page 26. Basic Log events may be viewed by following the procedure described in section 3.15, page 35.
- If it is necessary to remove the lid, first switch off the mains supply to the control panel. Ensure that the Power light is flashing, then use a suitable mains test instrument to confirm mains power is no longer present.
- **Enter the 4 digit Engineer code (? ? ? ?) and press (PROG.)** to access the Programming Menu and disable 24 Hour zones via the Engineer code. All the zone lights will illuminate.
- Remove the screw covers by inserting a screwdriver into the screw cover slot and turning anti-clockwise whilst applying pressure outwards.
- Unscrew the lid screws and remove the lid.
- On completion replace the lid and secure with the lid screws - **do not over-tighten**.
- Replace the screw covers.
- **Press (RESET)** to leave the Programming Menu. All the zone lights will turn off.
- Switch on the mains supply to the control panel. The Power light will stop flashing and stay on continuously.

2.7 Trouble Shooting

ALWAYS Ensure the mains is off BEFORE removing the front cover



When replacing a fuse always observe the specified rating and type - failure to do so is dangerous and will invalidate the warranty. Fuses should comply with IEC 127.

2.7.1 No Power to the Unit (Mains Only)

- Check the mains block fuse and replace if blown.
- Check for any loose wires at the mains block, the transformer and the AC terminals on the PCB.
- Check the mains block is connected correctly; live to live (brown), neutral to neutral (blue).

2.7.2 No Power to the Unit (Battery Only)

- Check the battery fuse F1 and replace if blown.
- Check for any loose wires at the BATT terminals on the PCB.
- Check that the battery wires are connected correctly; red from BATT+ to the battery positive (+), black from BATT- to the battery negative (-).

2.7.3 No Power to the Unit (Mains & Battery)

- Check the power supply output fuse F5 and replace if blown.
- Disconnect all wires from the control panel SAB A and AUX+ terminals.
- Check that links are only fitted in the correct places.
- Check there are no wires shorting to the underside of the PCB.
- Repeated blowing of the battery fuse F1 may indicate a faulty battery.

2.7.4 Unit Does Not Accept Code

- If using more than one RKP, check that each RKP has a different address.
- If using one or more RKPs, check that they are wired correctly.
- If the remote keypad was connected after the control panel was powered up, disconnect all power momentarily and reconnect. This automatically configures all remote keypads on the system, (see also section 3.8, page 27).
- Check you are using the correct codes. Factory-set Engineer code is ①②③④. Factory-set User code is ④③②①.
- If using one or more RKPs on battery only, try using mains as the battery may be flat.
- Check that the codes have not been changed. If the codes have been lost see section 3.6, page 26.
- Check that the membrane keypad tail is all the way home in its connector on the PCB.

2.7.5 Unit Will Not Set and Bleeps 10 Times

The Power light on the panel will be flashing to indicate a power fault, either mains fail or battery low volts.

- The mains frequency may be set incorrectly (section 3.2.4, page 24).
- The procedure for setting the system in the event of a power fault is described in the User Guide.

2.7.6 Unit Will Not Set and Bleeps 9 Times

The system has a tamper fault and the Tamper light will be on. Using the extended display during Walk Test (section 3.5, page 26) identify the cause of the tamper fault:

- If the extended display identifies the fault as an EOL tamper then identify the zone(s) from the normal display and check the zone wiring.
- If the extended display identifies the fault as bell box tamper, then the cause may either be Bell Tamper or Global System Tamper. Temporarily replace the system tamper link (TAMP):
 - If the tamper fault persists then it is due to the Bell Tamper - check the bell wiring, the bell lid and/or screw tamper, and the bell wall tamper (if fitted).
 - If the tamper fault clears then it is due to the system tamper. Remove the system tamper link and the tamper fault will reappear - check the system tamper wiring and the lid tamper on all detectors.
 - **Remove ALL temporary links.**
- If the extended display identifies the fault as lid tamper, it may refer either to the control panel or the remote keypad(s). Try stretching the springs and ensure all connections are secure.
- To set the system with a tamper fault use the following procedure:
- **Enter the User code** (???)?. Press (FULL) or (PART). The system will sound a repeating series of 9 beeps. Press (OMIT). The display will illuminate the zones that are about to be armed. Press (9). The Tamper light will turn off. Press (PROG.). The exit tone and exit timer will start.
- To prevent repeated false alarms due to an intermittent tamper fault when the system is unset, omit Tamper as described above, then abort the setting procedure by re-entering the User code.
- To prevent Tamper from being omitted see section 3.2.3, page 23.

2.7.7 Unit Will Not Set and Bleeps Between 1 & 8 Times

The system has one or more zone faults and the corresponding zone light(s) will be on.

- Ensure that the zone is closed (doors shut, no movement in PIR detection area).
- Check the zone wiring and ensure all connections are secure.
- Check that detectors are powered correctly (i.e. correct polarity).

2.7.8 Unit Goes Into False Alarm

- Check that the terminal screws are fully down on all terminals **but do not over tighten**.
- If you have a meter use it to check the loop resistance (wires that run under carpets are easily damaged).

2.7.9 Unit Makes No Sound

- Check that the variable resistor (pot) on the PCB which controls the volume of low level tones is NOT turned fully clockwise. The volume increases as the pot is turned anti-clockwise.
- Check the auxiliary fuse F3 and replace if blown.
- Check the speaker connections to the L/S terminals on the PCB.

2.7.10 System Operates but Remote Keypad Makes No Sound

- If an older version remote keypad has been fitted the system must be programmed for old style sounds as follows: **Enter the Engineer code** (???)?, press (PROG.), enter (00), press (8), press (PROG.), press (RESET).

2.7.11 The External Sounder or Strobe Does Not Work

- Check wiring connections by referring to the diagrams in section 2.4.2.1, page 12.
- Check the bell/strobe fuse F2 and replace if blown.
- To check the external sounder make a temporary connection between SAB B and D.
- To check the strobe make a temporary connection between SAB S and D.

2.7.12 The Panic Button Does Not Work

- Check that the Zone Type of the zone to which the panic button is connected is programmed as PA (section 3.10, page 28).
- Check that the zone to which the panic button is connected is not omitted in part set (section 3.16.2, page 36).
- Check that the Zone Type of the zone to which the panic button is connected is not changed in part set (section 3.11, page 31).
- Older version remote keypads do NOT support Keypad PA (pressing ③ and ⑨ together), see section 2.7.10, page 20.

2.7.13 The Service Timers Cannot Be Programmed

Programming the service timers (②⑦, ②⑧, ②⑨) is prevented unless the current date (②⑤) has been programmed since the last power-up (section 3.12.1, page 33).

3 Programming

Programming is usually unnecessary as the factory settings have been carefully selected to suit most installations without alteration. However all functions are fully programmable for Complete Control.

3.1 The Programming Menu

The Programming Menu can only be accessed when the control panel is unset. **Enter your 4 digit Engineer code (factory set to ①②③④). Press (PROG).** All the zone lights will illuminate. The various programming options are then selected by entering a 2 digit Option code (??). The Programming Procedure (section 1.1, page 4) then depends upon the programming option selected as detailed in the following sections. On completion, each programming option reverts to the Programming Menu, allowing other programming options to be accessed. To exit the Programming Menu **press (RESET)**, the system will revert to unset.



- 1) To abort programming at any stage (and preserve the original setting) press (RESET), the system will revert to the Programming Menu.
- 2) 24 Hour zones (Fire, PA and Tamper) are disabled when the Programming Menu is accessed via an Engineer code.
- 3) To omit zones, set chime or change the User code, refer to the User Guide.
- 4) The system programming is retained even in the event of complete loss of power.

3.2 Programming the Miscellaneous Selections

There are four sets of Miscellaneous Selections which control the behaviour of various system functions.

3.2.1 Miscellaneous Selections Zero ①①

From the Programming Menu, **enter ①①**. The zone lights of the options currently selected will illuminate. **Press the appropriate numbered button(s) to select or de-select the corresponding option(s) as shown on the display. Press (PROG).** The system will chime to confirm that the new options have been accepted. The system will then automatically revert to the Programming Menu and all the zone lights will illuminate.

Option	Miscellaneous Selections Zero	Factory Setting
1	Cancel Strobe with Bell	Off
2	Keypad PA (pressing ③ and ⑨ together causes PA alarm)	On
3	Single Button Setting	On
4	Silent Part Set Confirmation Tone	Off
5	EN50131-1 Requirements	Off
6	Time Limit Engineer Access	Off
7	Reset Button Cancels Setting	On
8	Old Style Veritas Sounds (must be selected for older version remote keypads)	Off



- 1) Single Button Setting (Option 3) allows the system to be set using the **FULL** or **PART** keys without the need to first enter a User code.
- 2) EN50131-1 Requirements (Option 5) invokes the following features (see section 4.8.1, page 46):
 - a) Reset (after an alarm) requires the use of a User code.
 - b) An entry alarm (defined as an entry timeout or, a Guard zone activation during the entry period) invokes a 30 second delay during which the communicator output and external sounder are suppressed (i.e. the alarm response is limited to the internal sounder(s) and external strobe for the first 30 seconds).
 - c) On unsetting the system the unset light will extinguish after 30 seconds.
 - d) On unsetting the system omitted zones will be re-included.
- 3) If Option 6 is selected the control panel will only accept Engineer codes for the first 30 seconds after the system is unset (i.e. while the Unset light is on if Option 5 is also selected).
- 4) Option 7 allows setting to be aborted by pressing the **RESET** button. It is particularly useful if Single Button Setting (Option 3) is selected but may be used independently.
- 5) Silent Part Set Confirmation Tone (Option 4) will only function if Silent Part Set (section 3.2.2, page 23) is also selected.
- 6) Option 8 must be selected if older version remote keypads are used.

3.2.2 Miscellaneous Selections One ①①

From the Programming Menu, **enter** ①①. The zone lights of the options currently selected will illuminate. **Press the appropriate numbered button(s) to select or de-select the corresponding option(s) as shown on the display. Press** **PROG.** The system will chime to confirm that the new options have been accepted. The system will then automatically revert to the Programming Menu and all the zone lights will illuminate.

Option	Miscellaneous Selections One	Factory Setting
1	Internal Sounders Only on Unset Tamper Alarm	On
2	Internal Sounders Only on Part Set Zone Alarm	On
3	Internal Sounders Only on Part Set Tamper Alarm	On
4	Silent Part Set (no exit tone on part set)	Off
5	High Level Chime (chime at full volume)	Off
6	Invert Bell Output (negative removed instead of negative applied, useful for SCBs)	Off
7	Final Door Set (system sets 3 seconds after final door closure)	Off
8	Unlock Engineer Code (re-loading factory settings restores default Engineer code)	On



- 1) If Option 8 is selected (Zone 8 light is on) then Re-loading the Factory Settings **WILL** restore the default Engineer code. If Option 8 is de-selected (Zone 8 light is off) then Re-loading the Factory Settings **WILL NOT** restore the default Engineer code.
- 2) Locked Engineer codes cannot be unlocked without the correct Boss Engineer code.
- 3) Unlocking a locked Engineer code that has been lost is subject to a minimum charge.



Disclaimer

It is the responsibility of the Installer to guard against losing locked Engineer codes. Texecom accept no liability whatsoever for any loss resulting from locked Engineer codes.

3.2.3 Miscellaneous Selections Two ①②

From the Programming Menu, **enter** ①②. The zone lights of the options currently selected will illuminate. **Press the appropriate numbered button(s) to select or de-select the corresponding option(s) as shown on the display. Press** **PROG.** The system will chime to confirm the new options have been accepted. The system will then automatically revert to the Programming Menu and all the zone lights will illuminate.

Option	Miscellaneous Selections Two	Factory Setting
1	Engineer Reset on Any Alarm (see section 3.2.5, page 24)	Off
2	Engineer Reset on Tamper Alarm (see section 3.2.5, page 24)	Off
3	Disable User Ability to Omit Tamper	Off
4	Code PIN Tamper (tamper alarm after 16 invalid key presses when unset)	Off
5	Random Number Remote Reset (RNRR, see section 3.2.5, page 24)	Off
6	Push To Set (see section 3.2.6, page 25)	Off
7	Strobe Flash on Full Set	On
8	Invert Switched Positive Output (off = negative removed, on = negative applied)	Off

3.2.4 Miscellaneous Selections Three ①③

From the Programming Menu, enter ①③. The zone lights of the options currently selected will illuminate. Press the appropriate numbered button(s) to select or de-select the corresponding option(s) as shown on the display. Press (PROG). The system will chime to confirm that the new options have been accepted. The system will then automatically revert to the Programming Menu and all the zone lights will illuminate.

Option	Miscellaneous Selections Three	Factory Setting
1	Mains Frequency (off = 50Hz, on = 60Hz)	Off
2	EOL Tamper Alarm on Zone Short Circuit (S/C)	Off
3	EOL Tamper Alarm on Zone Open Circuit (O/C)	Off
4	Engineer Reset on Power Up (see section 3.2.5, page 24)	Off
5	Reserved for Future Use	Off
6	Reserved for Future Use	Off
7	Automatically Omit Zone on Alarm	Off
8	Automatically Omit Keyswitch Zone when EOL Tampered	Off



- 1) If the wrong Mains Frequency is selected the panel will indicate a power fault.
- 2) Option 7 will prevent multiple alarms from the same zone. It should **NOT** be used if selecting non-latching communicator outputs (section 3.19.1, page 43).
- 3) Option 8 will prevent a key switch being used to unset the system if it is tampered with.

3.2.5 Engineer Reset

The following events can be programmed to require a subsequent Engineer Reset:

- Any Alarm (section 3.2.3, page 23)
- Tamper Alarm (section 3.2.3, page 23)
- Power Up (section 3.2.4, page 24)
- Service Timer Three Expiry (section 3.13.3, page 34)

Engineer Reset prevents the user from resetting the system. Engineer Reset can be cleared by:

- Entering an Engineer code
- Entering an RNRR code (if selected – section 3.2.3, page 23)
- Remote Reset (if selected - section 3.19.1, page 43)

Engineer Reset is not in itself a method of resetting the system - a subsequent User Reset will still be required. User Reset is accomplished by:

After an Alarm has been Silenced:

- Pressing (RESET) (unless EN50131-1 Requirements is selected – section 3.2.1, page 22)
- Entering a User code

At other times:

- Entering a User code and pressing **RESET**



- 1) When an Engineer Reset is required the user can still silence the alarm and cancel the strobe but cannot reset the system.
- 2) RNRR and Remote Reset are methods of clearing Engineer Reset. They will not function unless at least one Engineer Reset is selected.
- 3) If RNRR (sometimes called Anti-Code Reset or Scramble Reset) is selected then:
 - a) When an Engineer Reset is required, the zone lights will display a random 4 digit sequence. Each digit will flash in turn and then pause before repeating. Texecom's Anti-Code software will accept this sequence to generate a 4 digit code which should be entered, after which the system can be reset as normal. Anti-Code software is available from Texecom.
 - b) The user can press the **RESET** key to toggle between the RNRR display and the alarm display.
 - c) The User Guide has a section to fill in the phone number(s) where the user may obtain the Anti-Code.
 - d) Random Number Remote Reset satisfies the requirements of NACP 10, Issue 2, Section 11.2b.

3.2.6 Push To Set

Push to Set is intended to reduce false alarms due to user error when full setting the system. The user starts full set in the usual way and leaves the premises. However the system will ONLY set when an external push button is pressed.



- 1) The Zone Type of the zone to which the external push button is connected must be programmed as Push to Set (section 0, page 28):
 - a) If this zone is set to chime (see User Guide) then the push button can double up as a door bell.
 - b) If a normally open (N/O) push button is used then the zone should be inverted (section 3.16.7, page 37) so that it chimes when the button is pressed rather than when it is released.
 - c) The external push button should be waterproof unless it is located in an enclosed porch.
- 2) Push to Set does not operate in part set.
- 3) Push to Set satisfies the requirements of NACP 14, Issue 1, Section 2.1.2.

3.3 Programming the Number of Alarm Activations ①④

From the Programming Menu, **enter** ①④. All the zone lights will turn off. **Enter the desired number of Alarm Activations as a two digit number** (e.g. for three Activations, enter ①③). Zone 1 light will illuminate when the first digit is entered. Zone 2 light will illuminate when the second digit is entered. **Press** **PROG**. The control panel will chime to confirm that the new number of Activations has been accepted. The system will then automatically revert to the Programming Menu and all the zone lights will illuminate.



The total number of Activations should not be less than 01.

3.4 Testing the Sounders, Strobe and SW+ ①⑤

From the Programming Menu, **enter** ①⑤. All the zone lights will turn off. The system outputs may be tested as follows:

Key	Function
⑥	Invoke bell box hold-off mode
⑤	Toggle the SW+ output
④	Toggle the internal sounder at high level (alarm level)
③	Toggle the internal sounder at low level (entry/exit level)
②	Toggle the strobe output
①	Toggle the external sounder (bell) output
①	Turn off all of the above



- 1) The zone light corresponding to each output will illuminate when it is on.
- 2) Several Texecom bell boxes feature a unique, patented "Engineer Hold-Off Mode" which disables Self-Activate on Lid Tamper to facilitate convenient servicing. Option ⑥ will cause the strobe output to pulse 3 times to invoke Hold-Off Mode. Zone 2 light will flash to indicate the strobe pulsing after which Zone 6 light will illuminate to indicate that Hold-Off Mode has been invoked. (See bell box instructions for more details).

Press **RESET** to return to the Programming Menu. All the zone lights will illuminate.

3.5 Walk Testing ①⑥, ①⑨

The control panel has two Walk Test modes, Latching and Non-Latching. During Walk Test when any zone is opened the corresponding zone light will illuminate. When the zone is closed the zone light will go out in Non-Latching Walk Test, but will remain on in Latching Walk Test.

From the Programming Menu, **enter ①⑥ to select Non-Latching Walk Test, or ①⑨ to select Latching Walk Test.** Initially all the zone lights will turn off and the control panel will sound the quiet exit tone. When any zone is opened, the corresponding zone light will illuminate. The control panel will, in addition, sound a repeating series of beeps corresponding to the open zone number (i.e. Zone 1 beeps once, Zone 2 beeps twice, etc.). If more than one zone is open, the beeps will correspond to the highest zone number (e.g. if Zone 2 and Zone 6 are open, the control panel will beep 6 times).

Conduct a Walk Test by triggering each of the system's detection devices in turn and check that the control panel registers the corresponding zone as open.

If the Tamper light is on and the panel beeps 9 times an extended display reveals more information about the source of the tamper fault(s). To toggle between the normal display and the extended display **press OMIT**. The extended display is distinguished from the normal display by the Unset light being off. In the extended display the zone lights are interpreted as follows:

Zone Light	Description
1	Bell Tamper (including Global System Tamper)
2	Not Applicable
3	Lid Tamper (including RKP Lid Tamper)
4	Line Monitor
5	RKP Off-Line
6	Not Applicable
7	Not Applicable
8	EOL Tamper

To terminate Walk Test **press RESET**. The system will return to the Programming Menu and all the zone lights will illuminate.



Silent PA zones (section 3.10.1.7, page 30) are only displayed if Walk Test is accessed via an Engineer code.

3.6 Re-Loading the Factory Settings ①⑦

From the Programming Menu, **enter ①⑦.** All the zone lights will turn off. **Press PROG.** The system will chime to confirm that all the factory settings have been re-loaded into the Non Volatile Memory. The system will then automatically revert to the Programming Menu and all the zone lights will illuminate.

If the Engineer code has been lost, provided it has not been locked (section 3.2.2, page 23) **power down the system** (mains and battery). **Restore power**. All the indicator lights will illuminate for 10 seconds. **Press** (RESET), or SLOWLY press and release the panel lid tamper spring 3 times, before the indicator lights turn off. The factory settings have now been re-loaded into the Non Volatile Memory.



- 1) Unlocking a locked Engineer code that has been lost is subject to a minimum charge.
- 2) Re-loading factory settings will not clear the Event Log (see section 3.15.1, page 35).
- 3) The system will bleep each time the panel lid tamper spring is pressed and released during the first 10 seconds after power up.

3.7 Programming the Switched Positive Output ①⑧

From the Programming Menu, **enter** ①⑧. The zone light of the function currently selected will illuminate. **Press the number of the function required** from the following list. **Press** (PROG.). The system will chime to confirm the new function has been accepted. The system will automatically revert to the Programming Menu and all the zone lights will illuminate.

Number	SW+ Function
1	Set Positive (latching detectors)
2	Alarm Positive with Latching Sensor Reset (FTA detectors)
3	Latching Shock Sensor Auto-Reset (old style latching shock sensors)
4	Tamper
5	Mains Fail
6	Set Positive with Latching Sensor Reset (latching detectors)
7	Walk Test
8	Entry/Exit

If connecting multiple detectors to one zone then:

- Latching detectors will indicate which detector(s) activated during an alarm.
- First to Alarm (FTA) detectors will indicate which detector caused an alarm and which detectors were then activated during the alarm.

Option 3 would typically be used with older designs of latching shock sensor which do not have a Latch input and must be powered down to clear the Latch indication. In this case the detectors would be powered from the SW+ output.



- 1) If selecting one of the options which incorporate latching sensor reset (2, 3 or 6) the user can force a latching sensor reset, to clear the Latch/FTA indication, **by entering their code and pressing** (RESET).
- 2) The SW+ output can only sink (not source) current. If powering detectors from the SW+ output, connect the detector +Ve to AUX+ and the detector -Ve to SW+. It may be necessary to invert the SW+ polarity (section 3.2.3, page 23).

3.8 Configuring the Remote Keypad(s) ①⑨

From the Programming Menu, **enter** ①⑨. The control panel will turn on the zone lights corresponding to remote keypads (RKPs) that are currently configured and on-line, while flashing the zone lights corresponding to RKPs that are currently configured but off-line.

To update the configuration, **press** (PROG.). The control panel will scan for RKP addresses 1 to 6. As each RKP is detected the control panel will configure it as present and illuminate the zone light corresponding to its address.

To leave configuring, **press** (RESET). If the configuration has not been updated the panel will sound an error tone. The system will automatically revert to the Programming Menu and all the zone lights will illuminate.



- 1) NEVER set two RKPs to the same address.
- 2) Setting the address of an RKP is described in the remote keypad instructions.
- 3) If an RKP is configured but off-line the system will have a tamper fault.
- 4) ALWAYS power down the control panel when wiring a remote keypad (RKP).
- 5) If an older version remote keypad has been fitted the system must be programmed for old style sounds as follows: **Enter the Engineer code** ①①①①, **press** (PROG.), **enter** ①①, **press** ⑧, **press** (PROG.), **press** (RESET).

3.9 Detector Programmable Features ①①

Some Texecom detectors have one or more programmable features (A, B & C) which may be selected or de-selected by pulsing the SW+ output a preset number of times. There are ten options corresponding to different feature sets, invoked by the appropriate number of pulses, which will also be repeated whenever the panel is powered up, as follows:

Option	Number of Pulses	Corresponding Zone Light	Feature		
			A	B	C
①	0 (no pulses)	N/A (all off)	N/A	N/A	N/A
②	4	1	Off	Off	Off
③	5	2	On	Off	Off
④	6	3	Off	On	Off
⑤	7	4	On	On	Off
⑥	8	5	Off	Off	On
⑦	9	6	On	Off	On
⑧	10	7	Off	On	On
⑨	11	8	On	On	On
⑩	12	Tamper	Restore Detector Factory Settings		

From the Programming Menu, **enter** ①①. The zone light corresponding to the option currently selected will illuminate. **Press the number of the option required.** **Press** (PROG.). The zone light will flash as the SW+ output pulses after which the system will chime to confirm the new option has been accepted. The system will then automatically revert to the Programming Menu and all the zone lights will illuminate.

3.10 Zone Types

The Zone Type of a zone determines how the system will behave when the zone is opened.

3.10.1 Description of Zone Types

The Control Panel supports eight different Zone Types as follows:

Zone Type Number	Zone Type
1	Push to Set
2	Inhibited Entry
3	Guard
4	Fire
5	Tamper
6	Entry/Exit
7	Personal Attack (Panic)
8	Keypad

Each zone may be programmed with one of these Zone Types which are described in the following sections:

3.10.1.1 Push To Set ①

Push to Set is intended to reduce false alarms due to user error when full setting the system. The user starts full set in the usual way and leaves the premises. However the system will ONLY set when an external push button is pressed. The Zone Type of the zone to which the external push button is connected must be programmed as Push to Set.



- 1) The Push to Set option must also be selected (section 3.2.3, page 23).
- 2) If the zone is set to chime (see User Guide) then the push button can double up as a door bell:
- 3) If a normally open (N/O) push button is used then the zone should be inverted (section 3.16.7, page 37) so that it chimes when the button is pressed rather than when it is released.
- 4) The external push button should be waterproof unless it is located in an enclosed porch.
- 5) Push to Set does not operate in part set.
- 6) Push to Set satisfies the requirements of NACP 14, Issue 1, Section 2.1.2.

3.10.1.2 Inhibited Entry ②

Inhibited Entry is sometimes referred to as 'intermediate entry' or 'walk through'. Opening a zone with this Zone Type when the panel is set will cause an alarm. During entry mode, activations of a zone with this Zone Type are disregarded. This Zone Type would typically be used for a hall PIR when there is a magnetic contact on the front door.

3.10.1.3 Guard ③

Guard zones are sometimes referred to as 'intruder' zones. Opening a zone with this Zone Type when the system is set will cause an alarm. When the control panel is unset, Guard zones are ignored. In a typical system most zones would have this Zone Type.

3.10.1.4 Fire ④

This Zone Type is designed specifically for smoke detectors. Zones with this Zone Type are monitored constantly even when the panel is unset. If activated they will cause a unique alarm with a distinctive 'fire' tone on the internal speaker. In addition, the external sounder will be pulsed rather than sounding continuously in contrast to a normal alarm.

3.10.1.5 Tamper ⑤

Zones with this Zone Type are monitored constantly even when the panel is unset. If activated they will cause an immediate alarm. The Global System Tamper zone is factory-set to this Zone Type.



Programming options allow the Tamper alarm response to be limited to the internal sounder if the system is unset or part set (section 3.2.2, page 23).

3.10.1.6 Entry/Exit ⑥

Opening a zone with this Zone Type when the system is set will cause the control panel to start entry mode. This Zone Type would typically be used for a front door magnetic contact or, if one is not fitted, a hall PIR.



The Final Door Set option (section 3.2.2, page 23) will cause the exit time to be reduced to 3 seconds when an Entry/Exit zone is closed during exit mode. This option would typically be used only when there is a magnetic contact on the front door.

3.10.1.7 Personal Attack ⑦

This Zone Type is designed specifically for panic buttons. Zones with this Zone Type are monitored constantly even when the panel is unset. If activated, they will cause an immediate alarm, sounding both the internal and external sounders.



The Silent PA option (section 3.19.1, page 43) will modify this Zone Type to have a silent response (just activation of the PA channel on the communicator interface with no local audible or visible alarm response at all).

3.10.1.8 Keyswitch ⑧

This Zone Type is designed specifically for key switches. Zones with this Zone Type are monitored constantly. The key switch can be used to full set, unset, silence an alarm and reset the system.



- 1) Ensure that there are no 24 Hour zones (Fire, PA and Tamper) in fault when using a key switch to reset the system.
- 2) The state of a Keyswitch zone (open or closed) is unimportant, it is the change in state (from open to closed, or vice versa) which is monitored.
- 3) PA codes, Duress codes and Keypad PA are entered from a keypad and therefore cannot be reset by a key switch but only by entry of a valid User code.

3.10.2 Programming the Zone Type

Each of the eight Zone Types has an associated Zone Type number which is used when programming the Zone Type of a zone:

Zone Type Number	Zone Type
1	Push to Set
2	Inhibited Entry
3	Guard
4	Fire
5	Tamper
6	Entry/Exit
7	Personal Attack (Panic)
8	Keyswitch

To program the Zone Type of any zone **press ① followed by the zone number**. The zone light of the Zone Type number currently selected will illuminate. **Press the Zone Type number required. Press (PROG)**. The system will chime to confirm the new Zone Type has been accepted. The system will then automatically revert to the Programming Menu and all the zone lights will illuminate.

For example to program Zone 7 as a Guard zone, enter ①⑦, press ③, press (PROG).

Key	Description
①	Program Zone Type
⑦	Zone = 7
③	Zone Type = Guard
(PROG)	Program



A zone is often referred to by its Zone Type, e.g. a zone with the PA Zone Type would be referred to as a PA zone.

3.10.2.1 24 Hour Zone Types

24 Hour zones (Fire, PA and Tamper), Keyswitch zones and Push to Set zones should be monitored constantly.

When a zone is omitted the system no longer monitors opening and closing of that zone. The Full and Part Set Suites (section 3.16, page 35) provide a method of automatically omitting zones when the system is set. Once a zone is omitted it will not be re-included until the system is next set. It is important to ensure that 24 Hour zones (Fire, PA and Tamper), Keyswitch zones and Push to Set zones are not omitted by any of the Full or Part Set Suites or the Cleaner Suite.

The system can be programmed to automatically change the Zone Type of any zone into either Exit/Entry, Inhibited Entry or Guard on selected part sets (section 3.11, page 31). The change will persist until the system is unset. It is important to ensure that 24 Hour zones (Fire, PA and Tamper), Keyswitch zones and Push to Set zones are not changed on part set.



- 1) If EN 50131-1 Requirements is selected (section 3.2.1, page 22) then omitted zones will be re-included when the system is next unset.
- 2) When wiring a 24 Hour zone (Fire, PA and Tamper), such as a panic button, using EOL operation it may be more convenient to fit the EOL resistor(s) in the panel than in the detector.

3.11 Changing Zone Types when Part Setting

The Zone Type of any zone can be made to change when the system is part set. The Zone Type can be changed into either Entry/Exit, Inhibited Entry or Guard. It is also possible to program which part set(s) will cause the Zone Type to change. The change will persist until the system is next unset.

For example, the tables below show the factory settings:

Zone	Zone Type	Part Setting Changes Zone Type Into:		
		Entry/Exit ②①	Inhibited Entry ②②	Guard ②③
1	Entry/Exit			✓
2	Inhibited Entry	✓		
3	Guard			
4	Guard			
5	Guard			
6	Guard			
7	Guard			
8	Guard			

Zone 1 will change (from Entry/Exit) into Guard and Zone 2 will change (from Inhibited Entry) into Entry/Exit.

Part Set Number ②①	Zone Type Changes When Part Setting
Part Set 1	✓
Part Set 2	
Part Set 3	✓
Part Set 4	

These changes will occur when using Part Sets 1 and 3 but not when using Part Sets 2 and 4.



24 Hour zones (Fire, PA and Tamper), Keyswitch zones and Push to Set zones should be monitored constantly and should NOT be programmed to change when the system is part set.

3.11.1 Programming which Part Sets will Change Zone Types ②①

The Control Panel has four part sets. Zone Types will only be changed on selected part sets. For example the Control Panel is factory set with Part Sets 1 and 3 selected. Thus Zone Types will only be changed on Part Set 1 and Part Set 3, not on Part Set 2 or Part Set 4.

Enter ②①. The zone lights of the part sets currently selected will illuminate. **Press the appropriate numbered button(s) of the part set(s) to be selected or de-selected.** Press **PROG.** The system will chime to confirm that the new selection has been accepted. The system will then automatically revert to the Programming Menu and all the zone lights will illuminate.

3.11.2 Programming the Zones that will Change to Entry/Exit ②①

This suite defines the zones which will be changed into Entry/Exit zones on the selected part sets. For example the Control Panel is factory set with Zone 2 included. Thus the Zone Type of Zone 2 will be changed (from Inhibited Entry) into Entry/Exit on Part Sets 1 and 3.

Enter ②①. The zone lights of the zones which are currently included will illuminate. **Press the appropriate numbered button(s) of the zone(s) to be included or excluded.** Press **PROG.** The system will chime to confirm that the new suite has been accepted. The system will then automatically revert to the Programming Menu and all the zone lights will illuminate.

3.11.3 Programming the Zones that will Change to Inhibited Entry ②②

This suite defines the zones which will be changed into Inhibited Entry zones on the selected part sets. For example the Control Panel is factory set with no zones included. Thus no zones will be changed into Inhibited Entry.

Enter ②②. The zone lights of the zones which are currently included will illuminate. **Press the appropriate numbered button(s) of the zone(s) to be included or excluded.** Press **PROG.** The system will chime to confirm that the new suite has been accepted. The system will then automatically revert to the Programming Menu and all the zone lights will illuminate.

3.11.4 Programming the Zones that will Change to Guard ②③

This suite defines the zones which will be changed into Guard zones on the selected part sets. For example the Control Panel is factory set with Zone 1 included. Thus the Zone Type of Zone 1 will be changed (from Entry/Exit) into Guard on Part Sets 1 and 3.

Enter ②③. The zone lights of the zones which are currently included will illuminate. **Press the appropriate numbered button(s) of the zone(s) to be included or excluded.** Press **PROG.** The system will chime to confirm that the new suite has been accepted. The system will then automatically revert to the Programming Menu and all the zone lights will illuminate.

3.12 Programming the Date and Time



- 1) It is **ESSENTIAL** to program the current date (②⑤) and time (②⑥) for correct operation of the service timer(s) and the 250 Event Extended Log.
- 2) Programming the service timers (②⑦, ②⑧, ②⑨) is prevented unless the current date (②⑤) has first been programmed.
- 3) If the panel is completely powered down it will attempt to store the current time and date in NVM and continue from this point when it is powered up. However it may be also desirable to select the Engineer Reset on Power Up option (section 3.2.4, page 24).

3.12.1 Programming the Date ②⑤

From the Programming Menu, **enter** ②⑤. All the zone lights will turn off. **Enter the current date as a 6 digit number; Day, Day, Month, Month, Year, Year** (e.g. to program the 1st of June 1998 enter ①①①⑥⑨⑧). Zone lights 1, 2, 3, 4, 5 and 6 will illuminate in turn as each digit of the new date is entered. **Press** (PROG.). The system will chime to confirm the new date has been accepted. The system will then automatically revert to the Programming Menu and all the zone lights will illuminate.

3.12.2 Programming the Time ②⑥

From the Programming Menu, **enter** ②⑥. All the zone lights will turn off. **Enter the current time as a 6 digit number; Hour, Hour, Minute, Minute, Second, Second** using 24 hour format (e.g. to program 7 minutes and 3 seconds past 2pm (14:07:03) enter ①④①⑦①③). Zone lights 1, 2, 3, 4, 5 and 6 will illuminate in turn as each digit of the new time is entered. **Press** (PROG.). The system will chime to confirm the new time has been accepted. The system will then automatically revert to the Programming Menu and all the zone lights will illuminate.

3.13 Programming the Service Timers

The Control Panel features three service timers designed to facilitate the convenient support of service contracts.

Disclaimer:



It is the responsibility of the Installer to obtain prior written agreement from the Customer regarding any use of a Service Timer. Texecom accept no liability whatsoever for any dispute resulting from the use of Service Timers.

Service Timer One is designed to be used as a reminder. When it expires it turns on high level chime on all eight zones the first time the panel is set/unset.

Service Timer Two is designed to be used as a nuisance. When it expires it turns on high level chime on all eight zones every time the panel is set/unset.

Service Timer Three is designed to be used as a lockout. When it expires the panel will require an Engineer Reset (section 3.2.5, page 24).

Any one, any two, or all three timers can be programmed for the same or different dates. To disable a service timer simply program an invalid or expired date. Expired service timers are automatically cleared when an Engineer code is entered.



NOTE

- 1) It is essential to program the current date (②⑤) and time (②⑥) for correct operation of the service timer(s).
- 2) Programming the service timers (②⑦, ②⑧, ②⑨) is prevented unless the current date (②⑤) has first been programmed.
- 3) The user can turn off chime globally or on individual zones but where still selected it will remain at high level until reprogrammed by an Engineer.
- 4) When Service Timer Three expires it will turn chime off.

3.13.1 Programming Service Timer One (Reminder) ②⑦

From the Programming Menu, **enter** ②⑦. All the zone lights will turn off. **Enter Service Timer One (Reminder) date as a 6 digit number; Day, Day, Month, Month, Year, Year** (e.g. to program the 1st of April 1999 enter ①①①④⑨⑨). Zone lights 1, 2, 3, 4, 5 and 6 will illuminate in turn as each digit of the new date is entered. **Press** (PROG.). The system will chime to confirm the new date has been accepted. The system will then automatically revert to the Programming Menu and all the zone lights will illuminate.

3.13.2 Programming Service Timer Two (Nuisance) ②⑧

From the Programming Menu, enter ②⑧. All the zone lights will turn off. **Enter Service Timer Two (Nuisance) date as a 6 digit number; Day, Day, Month, Month, Year, Year** (e.g. to program the 25th of December 2000 enter ②⑤①②①①). Zone lights 1, 2, 3, 4, 5 and 6 will illuminate in turn as each digit of the new date is entered. **Press** (PROG.). The system will chime to confirm the new date has been accepted. The system will then automatically revert to the Programming Menu and all the zone lights will illuminate.

3.13.3 Programming Service Timer Three (Lockout) ②⑨

From the Programming Menu, enter ②⑨. All the zone lights will turn off. **Enter Service Timer Three (Lockout) date as a 6 digit number; Day, Day, Month, Month, Year, Year** (e.g. to program the 1st of January 2001 enter ①①①①①①). Zone lights 1, 2, 3, 4, 5 and 6 will illuminate in turn as each digit of the new date is entered. **Press** (PROG.). The system will chime to confirm the new date has been accepted. The system will then automatically revert to the Programming Menu and all the zone lights will illuminate.

3.14 Programming the Times ③?

The system has the following eight time delays and one test time which are all programmable:

Number	Time Delay
①	Full Set Exit Time (seconds)
②	Part Set Exit Time (seconds)
③	Full Set Entry Time (seconds)
④	Part Set Entry Time (seconds)
⑤	Bell Cut Off Time (minutes)
⑥	Part Set Error Tone Suspension Time (seconds)
⑦	Bell Delay Time (minutes)
⑧	Second Intruder Time (minutes)
⑨	Zone Soak Test Time (days)

To program any of the above, from the Programming Menu, **press** ③ **followed by the corresponding time delay number** (e.g. for the Part Set Entry Time, enter ③④). All the zone lights will turn off. **Enter the desired time as a two digit number** (e.g. for 5 seconds enter ①⑤). Zone 1 light will illuminate when the first digit is entered. Zone 2 light will illuminate when the second digit is entered. **Press** (PROG.). The system will chime to confirm the new time has been accepted. The system will automatically revert to the Programming Menu and all the zone lights will illuminate.



- 1) The Bell Delay Time ⑦ is the length of time after the alarm activation before the bell sounds. The Bell Cut Off Time ⑤ is the length of time for which the bell sounds.
- 2) The L/M input should be connected to 0V (AUX-) if not required, otherwise Bell Delay will not operate.
- 3) The Part Set Error Tone Suspension Time ⑥ would typically be used to suspend the error tone (indicating an open zone) to avoid disturbance when there are detectors on the part set exit route.
- 4) The Second Intruder Time ⑧ is the time after a zone opening during which a different zone opening will activate the Second Intruder output channel on the communicator interface.
- 5) The Zone Soak Test Time ⑨ is used in conjunction with the Zone Soak Test Suite (section 3.16.9, page 37).
- 6) Some bell boxes have a built in timer. In this case the bell will sound for either its built in time or the programmed cut-off time, whichever is the shorter.

3.15 The Seven Event Basic Log

The control panel has a Seven Event Basic Log which stores the last 7 alarm activations. The zone light of the zone which first caused the alarm activation will flash, and the zone lights of any subsequently opened zones will illuminate.

The Control Panel also incorporates a time and date stamped, non-volatile, 250 Event Extended Log which can neither be erased nor altered. The 250 Event Extended Log is accessed using an interface available from Texecom.



The date (section 3.12.1, page 33) and time (section 3.12.2, page 33) must be programmed for the 250 Event Extended Log to function correctly.

3.15.1 Clearing the Seven Event Basic Log ④①

From the Programming Menu, **enter** ④①. All the zone lights will turn off. **Press** (PROG). The system will chime to confirm that the Seven Event Basic Log has been erased. The system will then automatically revert to the Programming Menu and all the zone lights will illuminate.

3.15.2 Displaying the Seven Event Basic Log ④②

From the Programming Menu, **press** ④ followed by the number corresponding to the desired event, ① being most recent, ⑦ being least recent (e.g. to recall the second most recent event, enter ④②). The zone light of the zone which first caused the alarm activation will flash, and the zone lights of all subsequently opened zones (if any), will illuminate.

If the Tamper light is on or flashing, an extended display reveals more information about the source of the tamper alarm(s). To toggle between the normal display and the extended display, **press** (OM). The extended display is distinguished from the normal display by the Unset light being off. In the extended display the zone lights are interpreted as follows:

Zone Light	Description
1	Bell Tamper (including Global System Tamper)
2	Power Supply Fault
3	Lid Tamper (including RKP Lid Tamper)
4	Line Monitor
5	RKP Off-Line
6	Code PIN Tamper
7	Keypad PA (including PA Code Entered)
8	EOL Tamper

Press (RESET). The system will return to the Programming Menu and all the zone lights will illuminate.

3.16 Programming the Suites

The system has a Full Set Suite, four Part Set Suites, a Chime Suite, a Cleaner Suite, a Double Knock Suite, a Manual Omit Suite, a Zone Invert Suite, a Zone Disable Suite and a Zone Soak Test Suite all of which are programmable.

24 Hour zones (Fire, PA and Tamper), Keypress zones and Push to Set zones should be monitored constantly and should NOT be omitted by the Full or Part Set Suites or the Cleaner Suite.

3.16.1 Programming the Full Set Suite ⑤①

The Full Set Suite defines the zones that will be automatically included and excluded (omitted) when the system is full set. To program the Full Set Suite, **enter** ⑤①. The zone lights of the zones currently active in full set will illuminate (the zone lights of the omitted zones will remain off). **Press the appropriate numbered button(s) of the zone(s) to be included or excluded (omitted).** **Press** (PROG). The system will chime to confirm that the new Full Set Suite has been accepted. The system will then automatically revert to the Programming Menu and all the zone lights will illuminate.

3.16.2 Programming the Part Set Suites ⑤②

A Part Set Suite defines the zones that will be automatically included and excluded (omitted) when the system is part set. To program a Part Set Suite, **press ⑤ followed by the suite number ①, ②, ③, or ④** (e.g. to program Part Set Suite 2, enter ⑤②). The zone lights of the zones currently active in part set will illuminate (the zone lights of the omitted zones will remain off). **Press the appropriate numbered button(s) of the zone(s) to be included or excluded (omitted). Press (PROG).** The system will chime to confirm that the new Part Set Suite has been accepted. The system will then automatically revert to the Programming Menu and all the zone lights will illuminate.

3.16.3 Programming the Chime Suite ⑤⑤

The Chime Suite defines the zones that will be automatically included and excluded (omitted) when chime is turned on. To program the Chime Suite, **enter ⑤⑤**. The zone lights of the zones that will chime when chime is turned on will illuminate (the zone lights of the omitted zones will remain off). **Press the appropriate numbered button(s) of the zone(s) to be included or excluded. Press (PROG).** The system will chime to confirm that the new Chime Suite has been accepted. The system will then automatically revert to the Programming Menu and all the zone lights will illuminate.



For a description of how to turn Chime on and off see the User Guide.

3.16.4 Programming the Cleaner Suite ⑤⑥

The Cleaner Suite defines the zones that will be armed/disarmed when the panel is set/unset with a Cleaner code. To program the Cleaner Suite, **enter ⑤⑥**. The zone lights of the zones currently included in the Cleaner Suite will illuminate. **Press the appropriate numbered button(s) of the zone(s) to be included or excluded. Press (PROG).** The system will chime to confirm that the new Cleaner Suite has been accepted. The system will then automatically revert to the Programming Menu and all the zone lights will illuminate.



- 1) The Entry/Exit zone which the cleaner will use **MUST** be included in the Cleaner Suite.
- 2) For a description of programming the Access Codes and Access Levels see section 3.17, page 38.

3.16.5 Programming the Double Knock Suite ⑤⑦

From the Programming Menu, **enter ⑤⑦**. The zone lights of the zones currently included in the Double Knock Suite will illuminate. **Press the appropriate numbered button(s) of the zone(s) to be included or excluded. Press (PROG).** The system will chime to confirm the new Double Knock Suite has been accepted. The system will automatically revert to the Programming Menu and all the zone lights will illuminate.



- 1) The Double Knock Suite defines the zones that will be assigned a double knock attribute.
- 2) A zone should be assigned a double knock attribute when maximum false alarm protection is required. A zone with a double knock attribute must be activated either twice within 10 seconds or once for longer than 10 seconds in order to cause an alarm.
- 3) Double knock is not recommended for Entry/Exit zones.
- 4) Double knock will not operate with Push to Set or Keyswitch zones.
- 5) Double knock should **NOT** be used for Fire, Panic, or Tamper zones.

3.16.6 Programming the Manual Omit Suite ⑤⑧

The Manual Omit Suite defines the zones that may be manually omitted by the user. To program the Manual Omit Suite, **enter** ⑤⑧. The zone lights of the zones currently included in the Manual Omit Suite will illuminate. **Press the appropriate numbered button(s) of the zone(s) to be included or excluded. Press** **PROG.** The system will chime to confirm that the new Manual Omit Suite has been accepted. The system will then automatically revert to the Programming Menu and all the zone lights will illuminate.



- 1) To prevent the user from omitting 24 Hour zones (Fire, PA and Tamper) these would be excluded from the Manual Omit Suite.
- 2) Zones not included in the Manual Omit Suite will still be omitted if they are excluded in the Full or Part Set Suites.

3.16.7 Programming the Zone Invert Suite ⑤⑨

The Zone Invert Suite defines the zones that are normally open (N/O) rather than normally closed (N/C). To program the Zone Invert Suite, **enter** ⑤⑨. The zone lights of the zones currently included in the Zone Invert Suite will illuminate. **Press the appropriate numbered button(s) of the zone(s) to be included or excluded. Press** **PROG.** The system will chime to confirm that the new Zone Invert Suite has been accepted. The system will then automatically revert to the Programming Menu and all the zone lights will illuminate.



- 1) Most detectors are normally closed (N/C).
- 2) The most common normally open (N/O) sensor is a pressure pad.

3.16.8 Programming the Zone Disable Suite ④⑧

The Zone Disable Suite defines the zones that are not monitored. Disabled zones cannot cause either alarm or EOL tamper. A zone could be disabled:

- if it was not used,
- while waiting for a faulty detector to be replaced.

To program the Zone Disable Suite, **enter** ④⑧. The zone lights of the zones currently included in the Zone Disable Suite will illuminate. **Press the appropriate numbered button(s) of the zone(s) to be included or excluded. Press** **PROG.** The system will chime to confirm that the new Zone Disable Suite has been accepted. The system will then automatically revert to the Programming Menu and all the zone lights will illuminate.



If a zone is disabled in this suite it will be necessary to enter the suite again to re-enable it.

3.16.9 Programming the Zone Soak Test Suite ④⑨



Soak Test is used to prevent false alarms for a set period after a new installation or when a detector has been replaced. If a zone on Soak Test activates it will not cause alarm or activate the communicator interface but it will still be logged. Afterwards the zone will have a standing fault and will need to be omitted before the system can be set. After the Soak Test Time (section 3.14, page 34) zones that have not activated will be automatically removed from the Soak Test Suite.

The Zone Soak Test Suite defines the zones that are on Soak Test. To program the Zone Soak Test Suite, **enter** ④⑨. The zone lights of the zones currently included in the Zone Soak Test Suite will illuminate. **Press the appropriate numbered button(s) of the zone(s) to be included or excluded. Press** (PROG). The system will chime to confirm that the new Zone Soak Test Suite has been accepted. The system will then automatically revert to the Programming Menu and all the zone lights will illuminate.



- 1) Soak Test is not appropriate for Entry/Exit, Push to Set, or Keyswitch Zone Types and these zones will still be monitored as normal even if they are included in the Soak Test Suite.
- 2) Zones which fail Soak Test will be automatically added to the Manual Omit Suite (section 3.16.6, page 37) which should be checked after a Soak Test failure.
- 3) When the Soak Test Suite is programmed the Soak Test Time is started therefore this should be programmed first (section 3.14, page 34).
- 4) Zones that have failed Soak Test will be cleared when the Soak Test Suite is programmed.

If a Soak Test zone activates all subsequent zone activations will be logged as well. For example, zones 5, 6, 7 & 8 are on Soak Test. Zones 7 & 8 activate and are logged (zone light On). The user then returns via Zone 1, Zone 2 & Zone 3. These zones will all be logged as well but while Zone 2 & 3 lights will be On, Zone 1 light will be Flashing as this was the first non Soak Test zone to be activated. It is therefore recommended that the 250 Event Extended Log is always checked in the event of a Soak Test failure.

3.17 Assigning Access Codes

The Control Panel allows up to eight users to operate the alarm system, each user is assigned an "Access Code", "Access Level" and "User Number". **The figure below shows an example of users assigned to a typical alarm system:**



User Number: 1
Access Code: **4321**
Access Level: **Master User**
Access Type: **Customer**



User Number: 2
Access Code: **1234**
Access Level: **Boss Engineer**
Access Type: **Installer**



User Number: 3
Access Code: **5678**
Access Level: **User**
Access Type: **Customer**

4...7

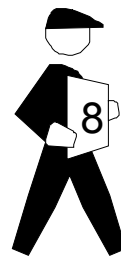

User Number: 8
Access Code: **2580**
Access Level: **Cleaner**
Access Type: **Customer**

3.17.1 User Number

Each user is identified by the alarm system as User 1 through to User 8.

3.17.2 Access Code

Each user has a programmable 4 digit Personal Identification Number (PIN) which the user enters in order to operate the alarm system.

3.17.3 Access Level

Each user has a programmable Access Level that determines how the alarm system responds and which of the system facilities the user can access.

Each Access Level has an associated number (1 – 8) which is used when programming the Access Level of a user.

There are eight possible user Access Levels:

3.17.3.1 User ①

A User may set, unset, silence an alarm and reset the system. In addition a User can test the system outputs (section 3.4, page 25), perform a Walk Test (section 3.5, page 26) and view the Basic Log (section 3.15, page 35). A User cannot change Access Codes (other than their own) or Access Levels.

3.17.3.2 Engineer ②

Engineers can access all the programming options with the exception of changing Access Codes (other than their own) or Access Levels.



An Engineer cannot lock or unlock Engineer codes (section 3.2.2, page 23).

3.17.3.3 Personal Attack ③

Entering a PA code will cause an immediate alarm, sounding both the internal and external sounders.

3.17.3.4 Duress ④

A Duress code behaves exactly as a User code (Level 1) but will in addition activate the Duress channel on the communicator interface to secretly summon assistance.

3.17.3.5 Master User ⑤

A Master User may set, unset, silence an alarm and reset the system. In addition a Master can test the system outputs (section 3.4, page 25), perform a Walk Test (section 3.5, page 26) and view the Basic Log (section 3.15, page 35). A Master User can also assign new Customer Access Code and Access Levels.

3.17.3.6 Cleaner ⑥

If the system is full set or part set then a Cleaner code will automatically omit the Cleaner Suite zones (section 3.16.4, page 36) without affecting the other zones. In addition pressing a key will NOT cause the system to start entry mode. On leaving the cleaner should enter their Access Code and press either **FULL** or **PART**. The **OMIT** key is disabled and the previous set will be restored irrespective of which key was pressed.

A cleaner cannot access chime. Nor can they cancel an alarm or reset the system.



- 1) When a cleaner is setting the system the Cleaner Suite zones will flash indicating that they are currently omitted but are about to be re-included. Any other omitted zones (e.g. if the system was previously part set rather than full set) will also flash but will NOT be included.
- 2) A Cleaner code should NOT be used if no zones are included in the Cleaner Suite (section 3.16.4, page 36).
- 3) If the system is unset then a cleaner can full set, part set and omit zones.

3.17.3.7 Null ⑦

The Null level is the only level which can be changed both by a Master User and by a Boss Engineer. The Null level has two functions:

- 1) If a user is no longer required, their Access Level should be changed to Null. This will erase the associated Access Code.
- 2) To change a Customer Access Type to an Installer Access Type, or vice versa, it must first be changed to the Null Code Type.

3.17.3.8 Boss Engineer ⑧

Boss Engineer level can access all the Engineer programming options and can also assign Access Level Engineer (Level 2).

3.17.4 Access Type

There are two Access Types, Customer and Installer. The Boss Engineer Level can only program the Installer Types. The Master User Level can only program the Customer Types.

The table below shows a summary of each Access Level and who is responsible for assigning the Level:

Access Level	Access Level Number	Access Type	Can be Programmed by
User	①	Customer	Master ④③②①
Engineer	②	Installer	Boss ①②③④
PA (Panic)	③	Customer	Master ④③②①
Duress	④	Customer	Master ④③②①
Master User	⑤	Customer	Master ④③②①
Cleaner	⑥	Customer	Master ④③②①
Null	⑦	Customer	Master ④③②①
		Installer	Boss ①②③④
Boss Engineer	⑧	Installer	Boss ①②③④

3.18 Programming Access Codes

Each user has a programmable 4 digit Personal Identification Number (PIN) which the user enters in order to operate the alarm system.

3.18.1 Changing Your Own Access Code ⑥①

Every user has the ability to change their own 4 digit Access Code, as follows:

From the unset state:

- 1) Enter your existing Access Code (?) (?) (?) (?)
- 2) Press PROG to access the Programming Menu (PROG)
- 3) Enter 60 to select the Change Your Access Code option (6) (0)
- 4) Enter your new 4 digit Access Code (?) (?) (?) (?)
- 5) Press PROG, the system will chime to confirm your new code (PROG)
- 6) Press RESET to revert to the unset state (RESET)

3.18.2 Assigning a New Access Code ⑥① – ⑥⑧

The Master User can assign a new Access Code or change an existing Access Code providing it is a Customer Type. The Boss Engineer can assign a new Access Code or change an existing Access Code providing it is an Installer Type.

From the unset state:

- | | |
|---------------------------------------------------------------|---------|
| 1) Enter your Access Code (Master User or Boss Engineer only) | ① ② ③ ④ |
| 2) Press PROG to access the Programming Menu | PROG. |
| 3) Enter 6 to select the Change Access Code option | ⑥ |
| 4) Enter the User Number (1 - 8) you wish to change e.g. 5 | ⑤ |
| 5) Enter their new 4 digit Access Code | ① ② ③ ④ |
| 6) Press PROG, the system will chime to confirm the new code | PROG. |
| 7) Press RESET to revert to the unset state | RESET |

3.18.3 Displaying Your User Number ⑥⑨

Each user is identified by the alarm system as User 1 through to User 8. Every user may view their User Number (1 - 8) as follows:

From the unset state:

- | | |
|---------------------------------------------------------------------|---------|
| 1) Enter your Access Code | ① ② ③ ④ |
| 2) Press PROG to access the Programming Menu | PROG. |
| 3) Enter 69 to select the Display Your User Number option | ⑥ ⑨ |
| 4) The zone light corresponding to your User Number will illuminate | |
| 5) Press RESET, the system will return to the Programming Menu | RESET |
| 6) Press RESET to revert to the unset state | RESET |

3.18.4 Changing Access Levels ⑦① – ⑦⑧

Each Access Level has an associated Number (1 – 8) as follows:

Access Level	Access Level Number	Access Type	Can be Programmed by
User	①	Customer	Master ④③②①
Engineer	②	Installer	Boss ①②③④
PA (Panic)	③	Customer	Master ④③②①
Duress	④	Customer	Master ④③②①
Master User	⑤	Customer	Master ④③②①
Cleaner	⑥	Customer	Master ④③②①
Null	⑦	Customer Installer	Master ④③②① Boss ①②③④
Boss Engineer	⑧	Installer	Boss ①②③④



The Master User can only assign Customer Access Types and the Boss Engineer can only assign Installer Access Types.

From the unset state:

- 1) Enter your Access Code (Master User or Boss Engineer only) (?) (?) (?) (?)
- 2) Press PROG to access the Programming Menu (PROG.)
- 3) Enter 7 to select the Change Access Level option (7)
- 4) Enter the User Number (1 - 8) you wish to change e.g. 5 (5)
- 5) Enter their new Access Level (1 - 8) e.g. 4 = Duress (4)
- 6) Press PROG, the system will chime to confirm the new Access Level (PROG.)
- 7) Press RESET to revert to the unset state (RESET)

3.18.5 Displaying Your Access Level ⑦⑨

Every user may view their own Access Level

From the unset state:

- 1) Enter your Access Code (?) (?) (?) (?)
- 2) Press PROG to access the Programming Menu (PROG.)
- 3) Enter 79 to select the Display Your Access Level option (7) (9)
- 4) The zone light corresponding to your Access Level will illuminate
- 5) Press RESET, the system will return to the Programming Menu (RESET)
- 6) Press RESET to revert to the unset state (RESET)



For security reasons the Duress Access Level will be displayed as the User Access Level.

3.19 Programming the Communicator Interface

The Control Panel features an eight output channel digital communicator interface with Line Monitor (L/M) and Remote Reset (R/R) inputs. The polarity of the outputs and the R/R input is programmable.



The L/M input should be connected to 0V (AUX-) if not required, otherwise Bell Delay will not operate.

3.19.1 Programming the Communicator Interface Selections ⑧①

From the Programming Menu, **enter** ⑧①. The zone lights of the options currently selected will illuminate. **Press the appropriate numbered button(s) to select or de-select the corresponding option(s) as shown on the display.** Press (PROG.). The system will chime to confirm the new options have been accepted. The system will then automatically revert to the Programming Menu and all the zone lights will illuminate.

Option	Communicator Selections	Factory Setting
1	Communicator Outputs Latch until System is Reset	On
2	Line Monitor Input causes Tamper Alarm on Line Cut	Off
3	Invert Communicator Outputs (off = active low, on = active high)	Off
4	Invert Remote Reset Input (off = active if negative removed, on = active if negative applied)	Off
5	Remote Reset Input Silences Internal Sounder during Alarm	Off
6	Remote Reset Input Clears Engineer Reset (section 3.2.5, page 24)	Off
7	Silent PA	Off
8	Enable 90 Second Abort Time Limit	On



- 1) The L/M input should be connected to 0V (AUX-) if not required, otherwise Bell Delay will not operate.
- 2) Do not use non-latching communicator outputs if selecting Automatic Omit (section 3.2.4, page 24).
- 3) Selecting Option 5 will enable the R/R input to be used to silence the internal sounder during an alarm (except a fire alarm) to facilitate Audio Verification (A/V).
- 4) It is valid to select both Options 5 and 6 if required.
- 5) Selecting Option 7 will cause PA zones (section 3.10.1.7, page 30) to have a silent response (just activation of the PA channel on the communicator interface with no local audible or visible alarm response at all).
- 6) If Option 8 is de-selected the system will send an abort whenever a valid code is first entered after an alarm activation. If Option 8 is selected the system will only send an abort if a valid code is entered within 90 seconds of an alarm activation.

3.19.2 Testing the Communicator Interface ⑧①

From the Programming Menu, **enter** ⑧①. The zone lights indicating the current status of the eight channels will illuminate. **Press the appropriate numbered button(s) to toggle one or more of the outputs.** Press (RESET) to return to the Programming Menu. All the zone lights will illuminate.

4 Technical Specification

4.1 Power Supply

Mains Supply Voltage Rating:	230V _{AC} /115V _{AC} ($\pm 10\%$) <small>see safety notes 1 & 2</small>
Maximum Total Current Rating	
230V _{AC} /115V _{AC} ($\pm 10\%$):	600mA _{DC} <small>see safety notes 1 & 2</small>
230V _{AC} /115V _{AC} ($\pm 5\%$):	1A _{DC} <small>see safety notes 1 & 2</small>
Ripple:	<5%
Rechargeable Battery Type:	12V Sealed lead acid gel type <small>see safety notes 3, 4 & 5</small>

4.2 Physical

Rechargeable Battery Capacity:	1.2 to 7.0Ah <small>see safety notes 3, 4 & 5</small>
Dimensions	282mm x 225mm x 80mm

4.3 Environmental

Operating Temperature:	-10°C (+14°F) to +50°C (+122°F)
Storage Temperature:	-20°C (-4°F) to +60°C (+140°F)
Maximum Humidity:	95% non-condensing <small>see safety note 6</small>
EMC Environment:	Residential/Commercial/Light Industrial or Industrial

4.4 Electrical

Current Consumption	
Quiescent Current:	<50mA
Alarm Current:	<150mA
Bell Saturation Voltage:	<1.0V _{DC} at 1.6A
Strobe Saturation Voltage:	<1.0V _{DC} at 1.6A
SW +Ve Output	
When Low:	<1.0V _{DC} at 1.6A
When High:	12V via 1k Ω
EOL Loop Thresholds (Zones 1 - 8)	
Low (Closed) Resistance:	10k Ω , 1%
High (Open) Resistance:	33k Ω , 1% (or 10k Ω , 1% + 22k Ω , 1%)
Negative Loop Threshold (Global Tamper)	
Minimum Open Resistance:	110k Ω
Maximum Closed Resistance:	20k Ω
Extension Speakers:	Minimum load 4 Ω

4.5 Fuses

A spare mains fuse is supplied in a clip adjacent to the mains terminal block. see safety note 7
 Spare PCB fuses are supplied in a press-seal bag. see safety notes 7 & 8

Mains 230V_{AC}:	T125mA, 250V, 20mm <small>see safety note 7</small>
Mains 115V_{AC}:	T250mA, 250V, 20mm <small>see safety note 7</small>
F1 (Battery Fuse):	F1A, 250V, 20mm <small>see safety note 7</small>
F2 (Bell & Strobe Fuse):	F1A, 250V, 20mm <small>see safety note 7</small>
F3 (L/S & Detector Auxiliary Fuse):	F500mA, 250V, 20mm <small>see safety note 7</small>
F4 (RKP Auxiliary Fuse):	F500mA, 250V, 20mm <small>see safety note 7</small>
F5 (Power Supply Output Fuse):	F1.6A, 250V, 20mm <small>see safety note 7</small>

4.6 Miscellaneous

Internal Speaker (50mm, 16Ω)

Low Level Volume:	Adjustable
High Level Volume:	>90dB at 1m

Loop Response Time

Minimum:	>200ms
Maximum:	<800ms

Remote Keypads:

Up to 6

Communicator Port:

8 Channel outputs
 Line Monitor input
 Remote Reset input

4.7 Safety Notes



- 1) Mains voltage is factory set and not adjustable - see label on transformer.
- 2) Removal of the transformer is prohibited and will invalidate the warranty.
- 3) Only use batteries of the specified type.
- 4) Dispose of used batteries safely according to the manufacturer's instructions.
- 5) Locate the battery inside the panel in the space provided.
- 6) This equipment is designed for dry indoor use only.
- 7) When replacing a fuse always observe the specified rating and type - failure to do so is dangerous and will invalidate the warranty. Fuses should comply with IEC 127.
- 8) The press-seal bag must NOT be stored inside the panel.

4.8 European Standards

Conforms to European Union (EU) Low Voltage Directive (LVD) 73/23/EEC (amended by 93/68/EEC) and Electro-Magnetic Compatibility (EMC) Directive 89/336/EEC (amended by 92/31/EEC and 93/68/EEC).

The CE mark indicates that this product complies with the European requirements for safety, health, environmental and customer protection.

4.8.1 EN 50131

In order to comply with EN 50131-1 several functional changes may be invoked using Miscellaneous Selections Zero, Option 5 (section 3.2.1, page 22). In addition the following points should be noted:

- In order to comply with EN 50131-1 Engineer access must first be authorised by a user, therefore Installer codes will only be accepted when the system is unset. If additional restriction is required then Engineer access may be time limited to the first 30 seconds after the system is unset (section 3.2.1, page 22).
- In order to comply with EN 50131-1 neither Internals Only on Part Set Zone Alarm nor Internals Only on Part Set Tamper Alarm should be selected (section 3.2.2, page 23).
- In order to comply with EN 50131-1 Single Button Setting should not be selected (section 3.2.1, page 22).
- In order to comply with EN 50131-1:
 - do not fit more than 10 unpowered detectors per zone,
 - do not fit more than one non-latching powered detector per zone,
 - do not mix unpowered detectors and non-latching powered detectors on a zone.
- In order to comply with EN 50131-1 the Entry Time should not be programmed to more than 45 seconds (section 3.14, page 34).
- In order to comply with EN 50131-1 the Bell Cut-Off Time should be programmed between 02 and 15 minutes (section 3.14, page 34).
- In order to comply with EN 50131-1 the Bell Delay Time should not be programmed to more than 10 minutes (section 3.14, page 34).
- EN 50131-1 requires that detector activation LEDs shall only be enabled during Walk Test. This is most conveniently achieved by using detectors with a Remote LED Disable input (e.g. the Texecom *Rf360*, *Rf650* & *RfExtreme* PIRs) connected to the panel SW+ output, programmed to operate during Walk Test (section 3.7, page 27).
- EN 50131-6 requires that the power supply output ripple should not exceed 5% at mains voltages down to 207V_{AC}. This limits the maximum rated output of the power supply to 600mA. The power supply can supply more than this at higher mains voltages or if greater ripple is accepted, for example at 230V_{AC} the power supply can deliver up to 1A.
- The standby time is the time for which the system power supply is capable of supplying its rated output current when running on battery only (i.e. in the event of mains failure). In order to comply with EN 50131-1 the standby time should be at least 8 hours for Grade 1 Systems and at least 15 hours for Grade 2 Systems. In order to comply with EN 50131-6 the Standby Time should be at least 12 hours for both Grade 1 and 2 Systems. For smaller battery sizes this means that the rated output of the power supply will actually be determined by the capacity of the standby battery and will be less than the power supply is capable of supplying (with the mains on). The rated output of the power supply may be calculated by dividing the capacity of the battery by the required standby time where the result is smaller than the maximum rated output of 600mA.

Rated output currents for typical battery sizes are shown in the following table:

Battery Capacity	Standby Time		
	1.2Ah	2.1Ah	3.0Ah
	150mA	100mA	80mA
	263mA	175mA	140mA
	375mA	250mA	200mA
	600mA	583mA	467mA



- 1) Engineer Reset prevents the user from resetting the system. It is not in itself a method of resetting the system.
- 2) EN 50131-1 separately defines Zone Inhibit and Zone Isolate optional facilities. The Zone Omit facility supported by the Control Panel corresponds to Inhibit. The Zone Disable facility supported by the Control Panel corresponds to Isolate.
- 3) When the battery voltage falls below the minimum system operating voltage it will be indicated as a power fault if the mains is on and will cause alarm if the mains is off.
- 4) The Control Panel Reset facility corresponds to the EN 50131-1 Restore function.
- 5) EN 50131-6 states that for integrated power supplies the environmental and tamper considerations of the control panel should be applied.

This equipment is designed to enable an intruder alarm system in which it is installed to comply with the requirements of security grades 1 or 2 of EN 50131-1, and EN 50131-6, and is suitable for installation in any indoor environment.

4.9 Warranty

All Texecom products are designed for reliable, trouble-free operation. Quality is carefully monitored by extensive computerised testing. As a result the Control Panel is covered by a two year warranty against defects in material or workmanship (details on request).

As the Control Panel is not a complete alarm system but only a part thereof, Texecom cannot accept responsibility or liability for any damages whatsoever based on a claim that the Control Panel failed to function correctly. Due to our policy of continuous improvement Texecom reserve the right to change specification without prior notice.

Veritas is a trademark of Texecom Ltd.

5 Installation Records

5.1 Installation Details

Installation Engineer: _____
 Installation Company: _____
 Address: _____

 Telephone: _____
 Installation Date: _____

Zone	Zone Type	Area Protected	Low Loop Resistance (Clear)	High Loop Resistance (Fault)
1				
2				
3				
4				
5				
6				
7				
8				

 The Instructions **MUST NOT** be Stored inside the Control Panel.

5.2 Maintenance & Call-Out Record

Date/Time	Reason for Site Visit	Work Carried Out	Name of Engineer

 The User Guide contains **ESSENTIAL SAFETY INFORMATION** and **MUST** be given to the user.

5.3 Access Code Table

User Number	User Name	Default Code PIN	Option to Change PIN	New Code PIN	Default Access Level	Option to Change Level	New Access Level
1		④③②①	⑥①		⑤ Master	⑦①	
2		①②③④	⑥②		⑧ Boss	⑦②	
3		N/A	⑥③		⑦ Null	⑦③	
4		N/A	⑥④		⑦ Null	⑦④	
5		N/A	⑥⑤		⑦ Null	⑦⑤	
6		N/A	⑥⑥		⑦ Null	⑦⑥	
7		N/A	⑥⑦		⑦ Null	⑦⑦	
8		N/A	⑥⑧		⑦ Null	⑦⑧	



- 1) Customer codes can only be programmed when the Programming Menu is accessed using a Master User code.
- 2) Installer codes can only be programmed when the Programming Menu is accessed using a Boss Engineer code.

Access Level	Access Level Number	Access Type	Can be Programmed by
User	①	Customer	Master ④③②①
Engineer	②	Installer	Boss ①②③④
PA (Panic)	③	Customer	Master ④③②①
Duress	④	Customer	Master ④③②①
Master User	⑤	Customer	Master ④③②①
Cleaner	⑥	Customer	Master ④③②①
Null	⑦	Customer	Master ④③②①
		Installer	Boss ①②③④
Boss Engineer	⑧	Installer	Boss ①②③④

5.4 Notes

5.5 Registered Installer Application Form



- 1) Partly Completed Forms CANNOT be accepted.
- 2) Please use Black Ink and Block Capitals.

Name: _____ Position: _____
 Company: _____ Fax: _____
 Tel: _____ E-Mail: _____
 Mobile: _____ Web Site: _____
 Address: _____

 _____ POSTCODE: _____

Which Distributors do you buy from? (Indicate at least one).

1	
2	
3	

How many Intruder Alarm Systems do you install on each month?

How many of the following Texecom products do you currently install each month?

Detectors:

Control panels:

External Sounder and Strobe Units:

Batteries:

Cameras:

Accessories:

Fax back to 01706 213187 or post to the address overleaf.

Alternatively register online at www.texecom.com

There's only ONE way to get

FREE

TECHNICAL SUPPORT...

REGISTER!

And receive the following exclusive benefits:

- **Access to the Secure Area of the Texecom Website**
 - **Freephone Technical Helpline***
 - **Free Product Voucher***
 - **Free Product Training***
 - **Latest Product Information**

Register online at www.texe.com or simply complete the form on the reverse of this page and return it to Texecom to become a Registered Texecom Installer.

***Available to UK Registered Installers only.**

Texecom
www.texe.com

Texecom Limited. Bradwood Court, St. Crispin Way, Haslingden, Lancashire BB4 4PW.

Website: www.texe.com

Technical Support (non-registered installers)

01706 212524

Calls charged at normal rate.