

## 8. SPECIFICATION

### LOAD

- 6 Amps fluorescent and incandescent lighting.
- 3 Amps compact fluorescent lighting.
- 3 Amps low energy lighting.
- 3 Amps low voltage lighting (switch primary of transformer).
- Switch SON lighting loads via a contactor.
- DD Digital Dimming output power supply versions - up to 10 dimming ballasts.
- AD Analogue Dimming output power supply versions - up to 10 dimming ballasts.

**SUPPLY VOLTAGE** 220-240 Volts AC 50 Hz

**LIGHT LEVEL** Light to dark

**TERMINAL CAPACITY** 1.5mm<sup>2</sup>

**MATERIAL** Sensor head, surface mount baseplate, flush bracket — Flame retardant ABS  
Power supply unit housing — Glass filled PA (polyamide)  
Flange mount bracket & Lens—PMMA (Clear acrylic)

**TYPE** Class 2

**TEMPERATURE** -10°C to 80°C

**SAFETY** The microwave radiation emitted by these units is extremely low power. At a distance of > 50mm the power density is <6% of the ANSI IEEE C95.1 –1991 recommended microwave power density. At a distance of 5mm from the unit it is <84% of recommended power density.

**CONFORMITY** EMC-89/336/EEC   
LVD-73/23/EEC

## 9. PART NUMBERS

### Sensor Head:

- MWS-5/SA Non-dimming sensor head (with mounting brackets included)
- MWS5-D “Direct dim” dimming sensor head (with mounting brackets included)

### Power Supply Unit:

- MWS5-PSU/SA Non-dimming power supply unit (suitable for MWS5/SA sensor head)
- MWS5-PSU-DD/SA Direct dim power supply unit (suitable for MWS5–D/SA sensor head) with DSI / DALI digital dimming output
- MWS5-PSU-AD/SA Dimming power supply unit (suitable for MWS5–D/SA sensor head) with 1-10V analogue dimming output

### Combined Sensor Head and Power Supply Unit:

- MWS5-PRM/SA/C Non-dimming sensor head and power supply
- MWS5-DD/SA/C Direct dim sensor head and power supply with DSI / DALI digital dimming output
- MWS5-AD/SA/C Dimming sensor head and power supply unit with 1-10V analogue dimming output

### Accessories:

- DD-LCDHS IR remote control programming handset with LCD screen
- UHS IR remote control user handset with lux and scene setting functionality
- UHS3 IR remote control user handset with on/off override only

### C.P. Electronics Ltd

Unit 2 Abbey Manufacturing Estate  
Mount Pleasant, Wembley  
Middlesex. HA0 1RR  
Tel: + 44 (0) 20 8900 0671  
Fax: + 44 (0) 20 8900 0674  
www.cpelectronics.co.uk

Due to our policy of continual product improvement CP Electronics reserves the right to alter the specification of this product without prior notice.



## PRODUCT DATA AND INSTALLATION SHEET



### MWS5-SA STAND ALONE MINIATURE CEILING MOUNTED MICROWAVE PRESENCE DETECTOR

## CONTENTS

Section	Contents	Page
1	Description and operation	1
2	Dimensions	2
3	Wiring	5
4	Setup	6
5	Programming	9
6	Detection pattern diagrams	11
7	Fault finding	11
8	Specification	12
9	Part numbers	12

## 1. DESCRIPTION AND OPERATION

The MWS5-SA series of miniature microwave presence detectors provide automatic control of lighting loads with optional manual control. The unit comes complete with a selection of fixing clips, allowing unobtrusive flush mounting of the sensor head into ceiling tiles or on to solid surfaces. It has been designed so that it can be used for ceiling mounted or wall mounted applications.

Three models are available: non-dimming MWS5, direct dim –DD and analogue dim –AD, all of which will switch incandescent, fluorescent and compact fluorescent lighting. The direct dim (DD) variant controls DSI or DALI digital dimming ballasts whilst the analogue dim (AD) variant controls 1-10V analogue dimming ballasts.

The unit detects movement using a microwave sensor and turns the load on. When an area is no longer occupied the load will switch off after an adjustable time out period has elapsed.

Feature	MWS5-SA (Non-dimming)	MWS5-DD/SA Direct Dim	MWS5-AD/SA Analogue Dim
Up to 8m microwave sensing	✓	✓	✓
3 mounting options	✓	✓	✓
Lux sensor	✓	✓	✓
Absence detection	✓	✓	✓
Presence detection	✓	✓	✓
Infrared remote setting	✓	✓	✓
Infrared user handset	✓	✓	✓
Push button adjustment*	✓	✓	✓
Relay output	✓	✓	✓
Dimming output		✓	✓
Absence switch input	✓	✓	✓
Up/down switch input		✓	✓

\*for lux, time and sensitivity

## 1. DESCRIPTION AND OPERATION CONT.

The product is supplied as two part numbers, and consists of the following parts:-

- Power Supply Unit
- Sensor Head with integral RJ11 sensor lead (300mm long) - plug into the separate power supply unit.
- Flush Mount Bracket
- Flange Mount Bracket
- Surface Mount Baseplate

The flush mount bracket, flange mount bracket and surface mount baseplate are all supplied with the sensor head. The power supply unit is packaged separately - therefore two part numbers need to be ordered.

The direct dim and analogue dim variants of the detector have a dimming output that can be used to control the light output of luminaires that are fitted with dimming ballasts. The detector measures the overall light level in the detection area and calculates the correct output for the luminaires, to achieve a preset lux level (maintained illuminance). The output level can be overridden using the switch input (see page 5) or the user handset.

All products support presence and absence detection:-

- Presence detection: when movement is detected the load will automatically turn on; when the area is no longer occupied the load will automatically switch off after an adjustable time period has elapsed.
- Absence detection: the load is manually switched on; when the area is no longer occupied the load will automatically switch off after the adjustable time period has elapsed.

### Switch operation:

- MWS5-SA using a single switch: single press and release turns on, single press and release to turn off.
- MWS5-DD/SA & MWS5-AD/SA using a single switch: single press and release to turn on, single press and release to turn off, press and hold cycles dimming.
- MWS5-DD/SA & MWS5-AD/SA using a two way switch: up button single press and release turns on, press and hold to dim up. Down button single press and release turns off, press and hold dims down.

All switches must be momentary contacts.

## 2. DIMENSIONS & MOUNTING OPTIONS

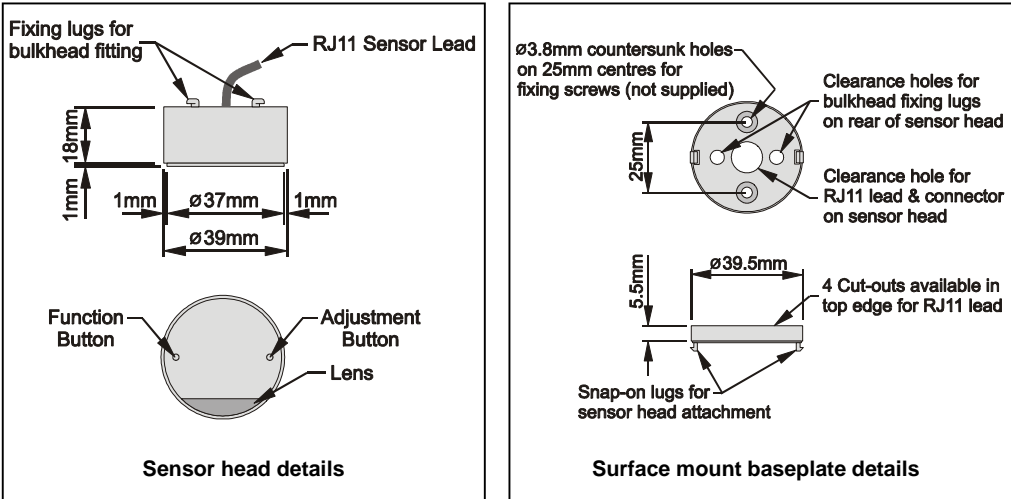

## 6. DETECTION PATTERNS

When ceiling mounting, the sensor will cover a floor area of approx. 8 metres diameter at an installed sensor height of 2.4 metres.

Please note that installing the sensor head behind a glass / polycarbonate diffuser will reduce the detection range by approximately 20%.

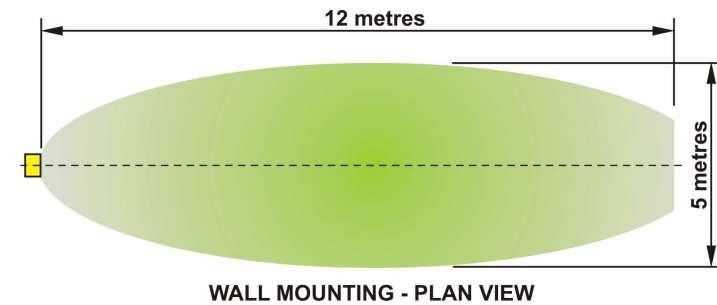
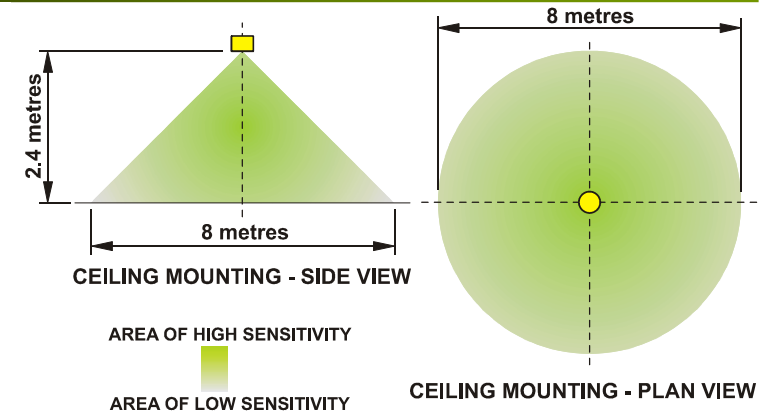

Please note that these approximate distances will apply with the sensitivity set to maximum.

## 7. FAULT FINDING

### LOAD DOES NOT COME ON

Check to see if the live supply to the circuit is good. Strap across the *L* and *LIVE OUT* terminal to turn the load on.

If the supply and wiring are good, check the LUX level setting. Increase the LUX level setting to allow the controller to turn on at higher ambient natural light level.

If the detection range is smaller than expected, check the diagram above. Rotating the sensor slightly may improve the range.

### LIGHTS DO NOT GO OFF

Ensure that the area is left unoccupied for longer than the selected timer setting.

Make sure that the sensor is not adjacent to circulating air, heaters or lamps.

If the unit "false triggers" reduce the sensitivity using the sensitivity settings (see section 5 and 6).

## 5. PROGRAMMING (CONTINUED)

### 4 Dimming Channel 2 functions -DD & -AD only (factory default in brackets):

- 4.1 Light level** Maintained illuminance level (adjustable between 1 and 999). At 999 the output will be always be at maximum.
- 4.2 Presence detection (default)** Auto switch on with detection, auto off after movement ceases and time delay ends.
- 4.3 Absence detection** Manual switch on, auto off after movement ceases and time delay ends.
- 4.4 Switch level on (9)** Lux level setting to prevent the luminaires being switched on if the ambient light level is sufficient (adjustable between 1 and 9). The luminaires will always be switched on at level 9.
- 4.5 Switch level off (9)** Lux level setting to switch the luminaires off during occupancy if the ambient light level goes above the setting (adjustable between 1 and 9). Level 9 will always keep the lights on. This setting can be used for "window row switching".
- 4.6 DSI (default)** Selects DSI dimming (not applicable on EBMPIR-AD)
- 4.7 DALI** Selects DALI dimming (not applicable on EBMPIR-AD)
- 4.8 Memorise (N)** If this is set to Yes, the last manual lux level set will be memorised and used as the new switch on level.
- 4.9 On value (99)** Dimming output level when switched on (0-99).
- 4.10 Off value (0)** Dimming output level when switched off (0-99). If set to anything other than 0 the light will not switch off but maintain a background lighting level.
- 4.11 Fade value (10)** After occupancy ceases, this dimming output level is loaded for the fade time (adjustable between 0 and 99).
- 4.12 Fade mins (0)** This is the time period (adjustable between 0 and 99 minutes) that the luminaire will be held at the fade value before turning off. A value of 0 disables the fade function.
- 4.13 Max value (99)** Maximum dimming output level (adjustable between 0 and 99).
- 4.14 Min value (1)** Minimum dimming output level (adjustable between 0 and 99).
- 4.15 Speed on (40)** Determines the dimming response speed after the setup time has finished. Measured in 0.1 sec intervals.
- 4.16 Speed set (5)** Determines the dimming response speed during the set up time. Measured in 0.1 sec intervals.
- 4.17 Set seconds (120)** Determines how long the dimming response set-up period lasts on power-up or on setting change (adjustable between 1 and 999 seconds). This enables the desired lux level to be achieved rapidly when the lights come on, or during setup.

### 5 User Menu

DD-LCDHS user menu or UHS handset functions:

- 5.1 Lux up** Increase light level. Reverts when occupancy cycle complete.
- 5.2 Lux down** Decrease light level. Reverts when occupancy cycle complete.
- 5.3 Scene up** Steps up between 6 pre-defined scenes.
- 5.4 Scene down** Steps down between 6 pre-defined scenes.
- 5.5 Scene#** Select the individual scene, between 0 and 6. (1 = min. output; 2 = 10%; 3 = 25%; 4 = 50%; 5 = 75%; 6 = 100%)
- 5.6 Override on** Permanently overrides the luminaire output on.
- 5.7 Override off** Permanently overrides the luminaire output off.
- 5.8 Cancel** Cancels the on or off override, returning the detector to normal operation.
- 5.9 Set** If sent before using lux up or lux down, it will set the light level as in 4.1

## 2. DIMENSIONS & MOUNTING OPTIONS CONT.

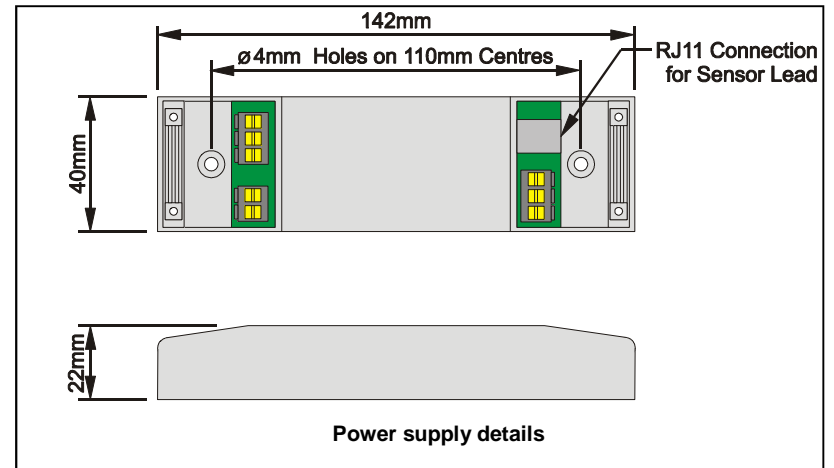

### Flush mounting the sensor head using the flush mount bracket

The product can be mounted into a ceiling tile or plasterboard ceiling using the flush mount bracket as shown below. If flush mounting in a panel that is greater than 6mm thick, remove bottom of retention arms with side cutters. A 44mm diameter hole will be required in the panel to mount the flush mount bracket.

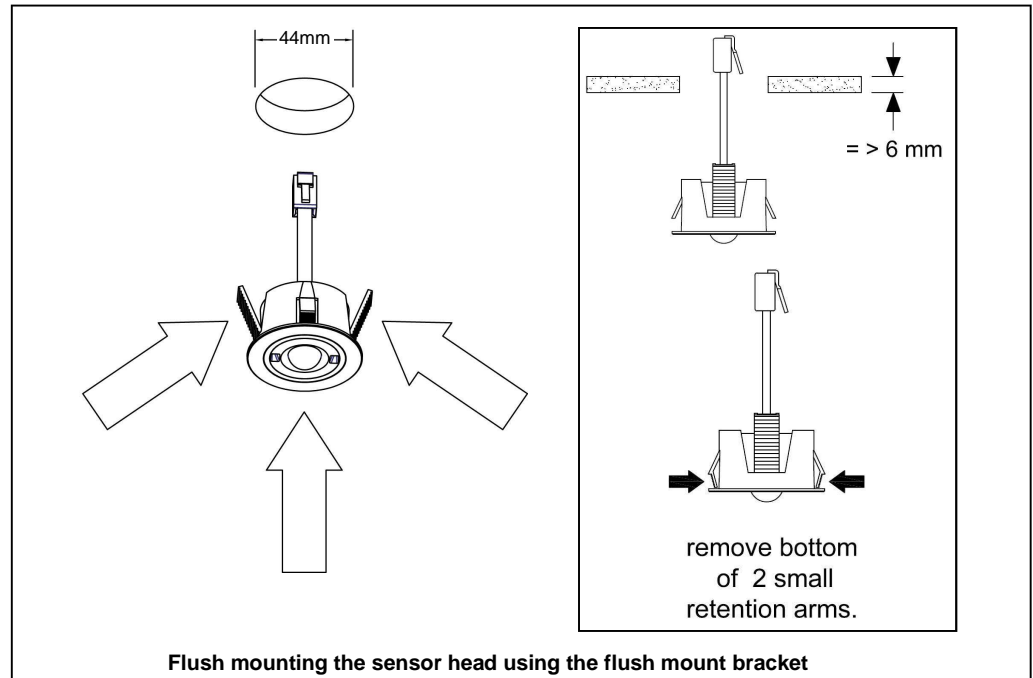

## 2. DIMENSIONS & MOUNTING OPTIONS CONT.

### Flush fitting behind light fitting diffuser using the flange mount bracket

Glue the flange mount bracket on to the rear of the diffuser, and fasten the sensor head in place using the two longer (19mm high) bracket clips.

Before gluing, please ensure that the glue used is compatible with both the acrylic flange mount bracket and the diffuser material.

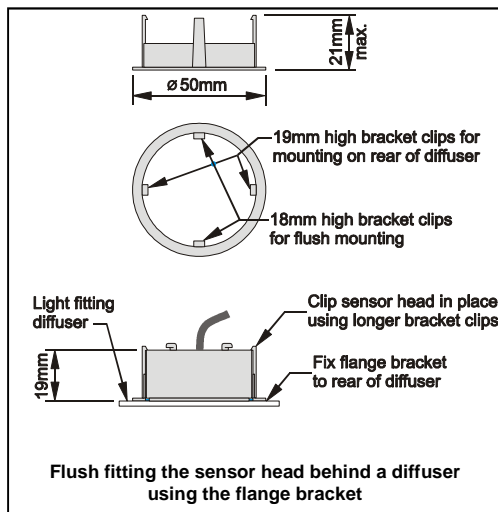

### Flush fitting through gear tray or metal bulkhead using the flange mount bracket

Cut a 37.5mm diameter hole in the bulkhead plate (max. 1mm thick) to allow the front face of the sensor head to pass through.

Glue the flange mount bracket on to the rear of the plate, and fasten the sensor head in place using the two shorter (18mm high) bracket clips.

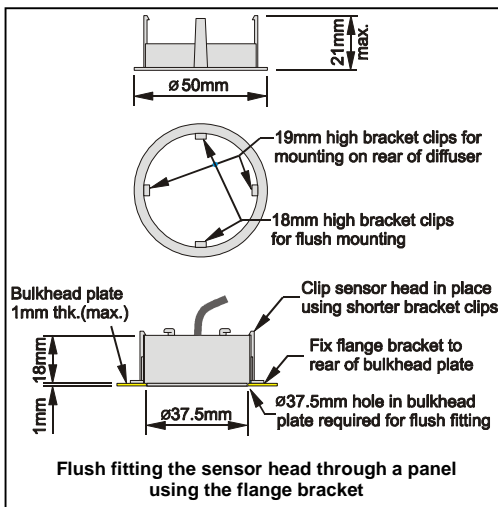

## 5. PROGRAMMING

All the following functions can be programmed using the remote control DD-LCDHS handset:

### 1. Detector Parameters (factory default in brackets):

- |     |                                 |   |
|-----|---------------------------------|---|
| 1.1 | <b>Time adjustment</b> (20 min) | 10 seconds to 99 minutes time delay (select 0 for 10 second delay – use for commissioning only).  |
| 1.2 | <b>Sensitivity On</b> (9)       | Sensitivity level when the detector is already operational adjustable between 1 (min.) and 9 (max.)   |
| 1.3 | <b>Sensitivity Off</b> (9)      | Sensitivity level for switching the detector on – adjustable between 1 (min.) and 9 (max.).   |
| 1.4 | <b>Power Up On</b> (Y)          | Select No for a 30 second delay on start up. If Yes is selected, there will be no delay on start up and the detector will always power up detecting.                  |
| 1.5 | <b>Walk Test</b> (N)            | An LED behind the detector lens will flash to show movement has been detected (use for commissioning).  |
| 1.6 | <b>Disable Detector</b> (N)     | Disables detection, leaving the relay output permanently off with the dimming output operational. This mode is used when the unit is for maintained illuminance only. |
| 1.7 | <b>Factory Default</b>          | Restores factory default settings.  |

### 2. Modes (factory default in brackets):

#### 2.1 Channel Modes

- |       |  |   |
|-------|--|---|
| 2.1.1 | <b>Switch only</b>                       | N/A   |
| 2.1.2 | <b>Switch and dim together</b> (default) | The detector will switch and dim the lighting together. |
| 2.1.3 | <b>Switch and dim separate</b>           | N/A   |

#### 2.2 Switch Modes

- |       |   |  |
|-------|---|--|
| 2.2.1 | <b>2 position switch together</b> (default -DD & -AD) | A single centre biased retractive switch will be used to control both channels together. |
| 2.2.2 | <b>2 position switch separate</b>                     | N/A  |
| 2.2.3 | <b>1 position switch together</b> (default MWS5)      | A single position retractive switch controls both channels together.                     |
| 2.2.4 | <b>1 position switch separate</b>                     | N/A  |

### 3. Switching Channel 1 functions (factory default in brackets):

(-DD & -AD—this channel controls the relay output, whereas Channel 2 controls the dimmed output. The parameters below should be programmed as well as the corresponding parameter on Channel 2)

- |     |                             |   |
|-----|-----------------------------|---|
| 3.1 | <b>Presence detection</b>   | Auto switch on with detection, auto off after movement ceases and time delay ends.  |
| 3.2 | <b>Absence detection</b>    | Manual switch on, auto off after movement ceases and time delay ends.   |
| 3.3 | <b>Switch level on</b> (9)  | Lux level setting to prevent the luminaires being switched on if the ambient light level is sufficient (adjustable between 1 and 9). The luminaires will always be switched on at level 9.  |
| 3.4 | <b>Switch level off</b> (9) | Lux level setting to switch the luminaires off during occupancy if the ambient light level goes above the setting (adjustable between 1 and 9). Level 9 will always keep the lights on. This setting can be used for “window row switching” with the DD unit. |

## 4. SETUP CONT.

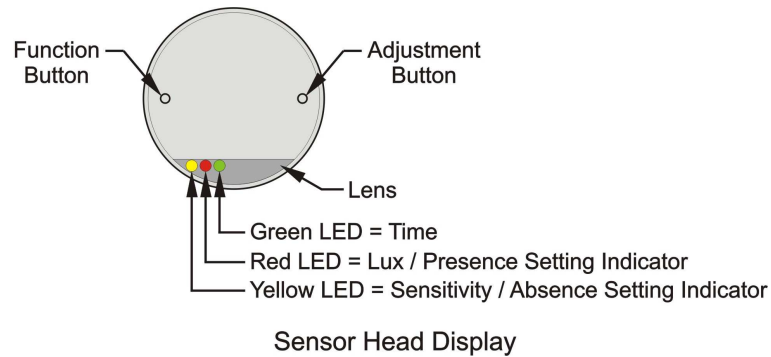

### Push button adjustment

#### Time, Lux and Sensitivity

- Press and hold either button for at least 5 seconds then release: one of the LED's positioned behind the lens will flash to show which function has been selected.
- The LED will flash a number of times (between 1 and 7) to indicate the current setting (minimum = 1 flash, maximum = 7 flashes).
- To change between Time (green), Lux (red) and Sensitivity (yellow) press and release the function button until the required LED shows.
- When the function has been selected press the adjustment button to increase the setting by 1 step. Pressing the button after reaching 7 flashes will return the setting to 1 flash.
- Time settings** are as follows: 1 flash = 1 minute; 2 flashes = 5 min.; 3 flashes = 10 min.; 4 flashes = 15 min.; 5 flashes = 20 min.; 6 flashes = 25 min.; 7 flashes = 30 min.
- Lux settings**  
**MWS5** — 1 flash turns on when very dark ; 7 flashes turns on regardless of ambient light.  
**-DD & -AD (Dimming)** — 1 flash gives dim output level; 7 flashes gives maximum illuminance.
- Sensitivity:** 1 flash minimum; 7 flashes maximum.
- After finishing adjustment, the LED will show the new setting 5 times and then return to operational mode.

#### Default settings

- Press and hold both buttons together: after 3 seconds the green LED lights. Release immediately to restore the factory settings. Then isolate the supply, leave powered down for approximately 10 seconds and then re-power up the unit - the factory default settings will then be restored.

#### Programming handset adjustment

If programming is to be completed using the infra-red programming handset (Part No. DD-LCDHS) please refer to section 5 (pages 9 and 10) for functionality, settings and programming parameters.

## 3. WIRING

Wire the products as shown in the diagrams below. All switches are optional with presence detection, but a switch will be required for absence detection. The dimming variants can have two switch configurations. If used with Option A, a single momentary switch can be used for absence detection and dimming up/down—set switch mode 1 position switch together (see section 5). If used with Option B (the default setting), a centre biased momentary switch gives the benefit of having separate switches to dim up and down—set switch mode 2 position switch together in this case. The DD-LCDHS programming handset will be required to change the switch type if Option A is required for dimming applications.

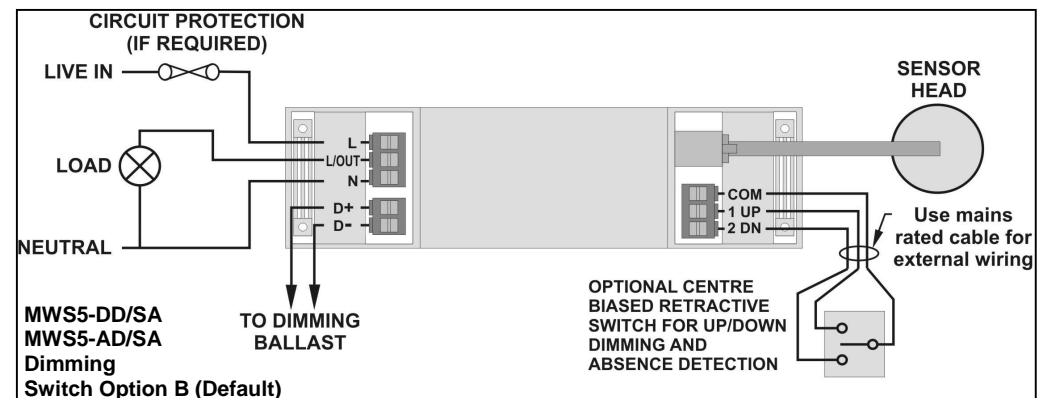
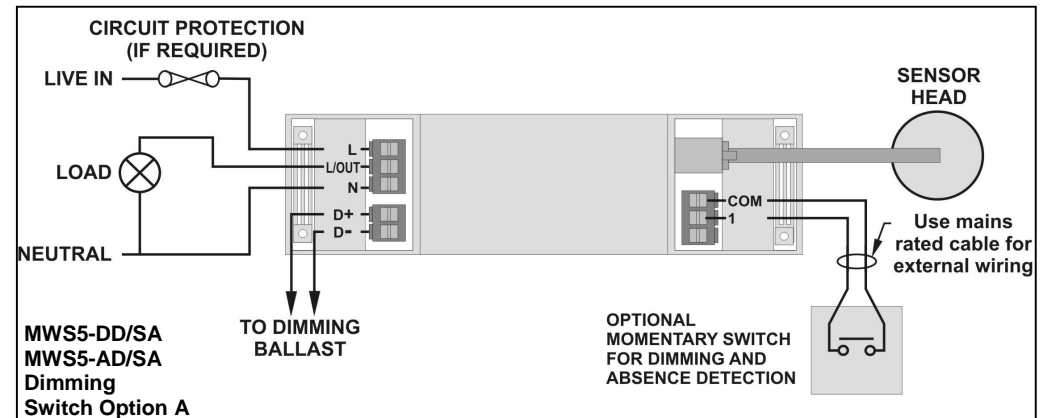
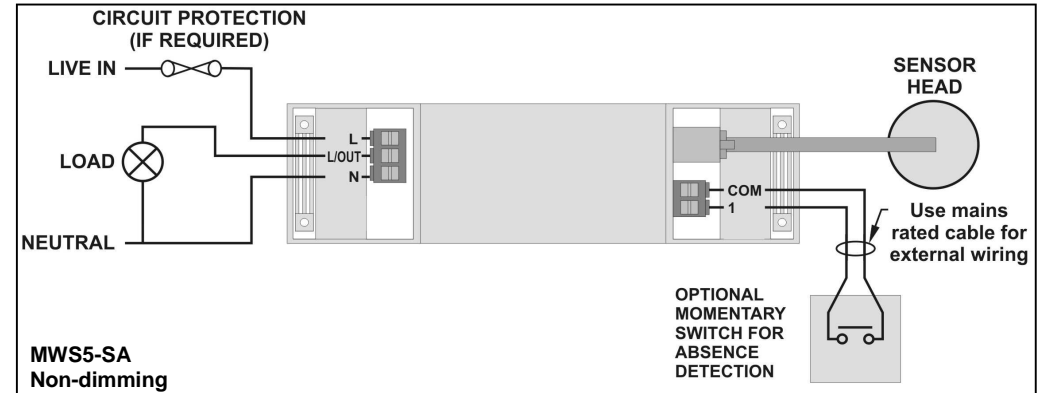

### 3. WIRING CONT.

1. Connect the power supply via the terminal block on the power supply unit as shown overleaf. Live supply to the **L** terminal, Neutral to the **N** terminal and the load to the **LIVE OUT (LO)** terminal.
2. Connect the sensor head to the power supply unit using the RJ11 connector, ensuring it “clicks” in place.
3. In the case of dimming applications, connect the **D+** (dimming up) and **D-** (dimming down) connections to the corresponding terminals on the luminaire dimming ballast.
4. Connect any manual switch that may be required as shown on page 5 overleaf. If Absence control is required, a momentary action contact switch must be connected in order to switch the load on. Please note that any cables that are connected to manual switches must be 240Vac “mains” rated to comply with IEE wiring regulations.
5. Fit the covers back on, ensuring all cables are secured using the integral cable clamps.
6. On power up, the load should come on immediately.
7. Vacate the room or remain very still and wait for the load to switch off (on the factory preset, this should take approximately 15 minutes, but the timing out period can be adjusted down to 1 minute to help speed up the setup procedure — please see next section for details on set-up & adjustment).
8. Check that the load switches on when movement is detected.

### 4. SETUP

#### Positioning

- The detector should be sited so that the occupants of the room fall inside the detection pattern shown in section 6 (page 11). Please note that when ceiling mounting, the recommended ceiling height of the sensor head is 2.4m. Note that the lower the sensor is installed the smaller the detection range will be, subject to the parameters shown on the diagram.
- Avoid direct sunlight entering the sensor.
- Do not site within 1m of forced air heating or ventilation.
- Do not fix to a vibrating surface.
- Avoid metallic objects directly in front of the sensor head.

### 4. SETUP CONT.

#### Settings adjustment:-

- On initial power up, the factory set default settings are:-
- Presence Detection mode.
- Time = 20 minutes.
- Lux = Maximum (i.e. lights will switch on in full daylight on detection).
- Sensitivity = Maximum.

#### Presence or Absence detection mode

- The unit ships with presence detection as default.
- To check the mode press and hold both buttons together: after 3 seconds the green LED lights up — leave the buttons pressed. After a further 3 seconds the following LED's will light:
  - Green/Yellow = Presence Detection mode
  - Green/Red = Absence detection mode
- To accept the current mode release the buttons immediately.
- To change the mode keep the buttons pressed for another 5 seconds until the LED's change, then release.

#### Time

**All versions** — set the time period using the push button adjustment overleaf or the programming handset (see section 6). The factory default is 20 minutes.

#### Lux

**MWS5 (Non-dimming)** — the **switch level on** lux setting determines the ambient light level at which the lights turn on. This can be set using the push button adjustment overleaf or the programming handset (see section 6). Setting to maximum (level 7) ensures that lights always come on (this is also the default setting).

**-DD & -AD (Dimming)** — **switch level on** described above is available using the programming handset only. The push button lux adjustment determines the dimming output level and can be set using push button the programming handset *light level* and works as follows:

- During operation the output level varies very gradually. However when the level is changed the unit automatically enters setup mode: in this mode the output level varies rapidly. After the setup time the unit reverts to normal.
- When adjusting, allow the output level to settle by changing very gradually.
- To disable the maintained illuminance function completely, set the level to maximum.

#### User handset

Using the UHS or UHS3 infra-red handset: the override on button turns the unit on permanently; the override off button turns the unit off permanently; the cancel button cancels the overrides. When an override is selected an LED will flash inside the unit. The UHS handset can also be used to set the lux levels (see section 5).