

LED 1W EMERGENCY DOWNLIGHT FITTING INSTRUCTIONS

These instructions are for the Déluce Lighting 1W LED Emergency Downlight :

DLDP1WNMLED

IMPORTANT INSTALLATION INFORMATION

- Installation should be carried out in accordance with the latest edition of the IEE Wiring Regulations (BS7671) and taking into consideration the latest Building Regulations. If in doubt, consult a qualified electrician.
- **Before commencing any installation or maintenance work, ensure electricity is switched off at the mains.**
- Please take note of the maximum rated voltage for your LED 1W Emergency Downlight.
- Please take note of the IP (Ingress Protection) rating of your LED 1W Emergency Downlight when deciding location.

GENERAL INSTALLATION - SAFETY

- Please make sure you are safe when working at height.
- Employ the latest safety regulations and procedures to ensure the safe installation of this LED 1W Emergency Downlight.

INSTALLATION INSTRUCTIONS

- To achieve the best results from your LED 1W Emergency Downlight we suggest you take into account the following points before you fit the unit.
- Do not fix to a surface where vibration is possible or may occur.

1. Switch off the Mains supply at the main fuse/distribution box, ensuring there is no power to the LED 1W Emergency Downlight.
2. Mark the position on the ceiling for the downlight and cut a 35mm Ø diameter hole, see Fig. 1 [maximum thickness = no more than 10mm].
3. Feed the supply cable through the hole and make the electrical connections to the charging unit as follows:

LIVE - (Red or Brown) to Terminal Marked L

NEUTRAL - (Black or Blue) to Terminal marked N

EARTH - (Green/Yellow) for Class I fittings to Terminal marked E ⊕

4. Connect the Battery pack to the charging unit via the push fit connector, then connect the LED 1W Emergency Downlight to the charging unit via the push fit connector as show below.
5. Feed both the charging unit and battery pack through the drilled hole into the ceiling void, making sure that NO insulation or any other material cover the 2 units which may cause them to over heat.
6. Squeeze the securing wings of the downlight and keep hold whilst inserting into the drilled ceiling hole.
7. The battery is supplied UNCHARGED, and must be charged for 24 hours before use, and is designed to last for 3 years [replace with a similar battery of same specification
8. Switch on the power supply for testing and adjustment.

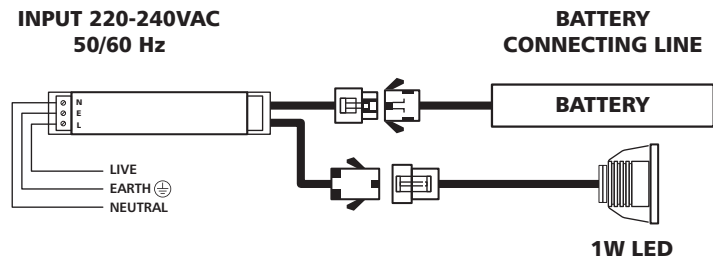

220-240V LED IP20 CE

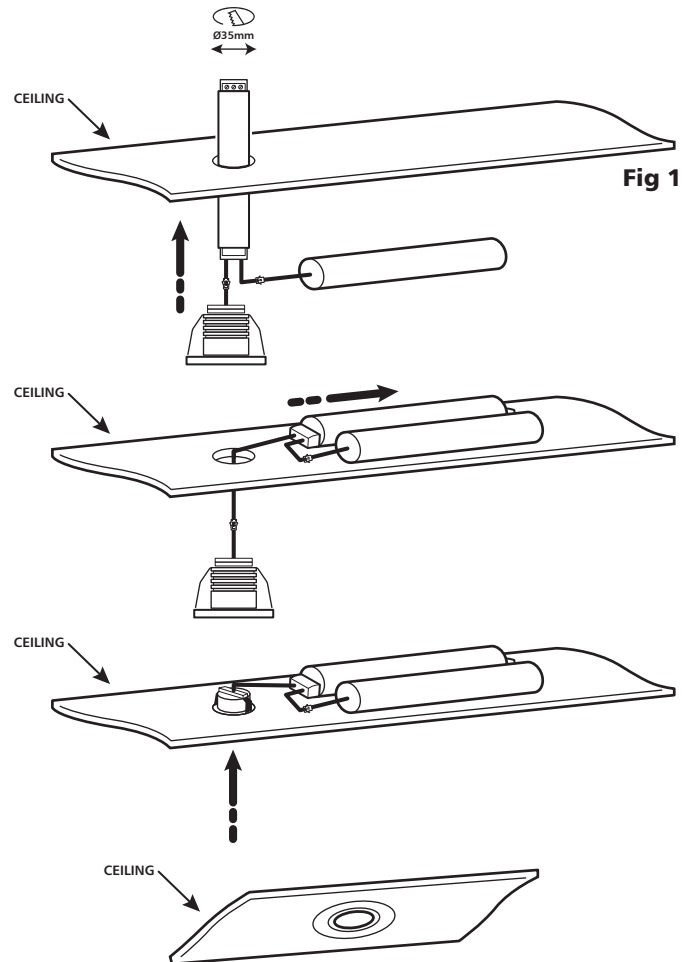

GUARANTEE

This product is guaranteed in the EU for a period of 1 year from the date of purchase. The guarantee is invalid in the case of improper use, installation, tampering, removal of the QC date label, installation in an improper working environment or installation not according to the current edition of the IEE Wiring Regulations (BS 7671). Should this product fail during the guarantee period it will be replaced free of charge, subject to correct installation and return of the faulty unit. Déluce Lighting does not accept responsibility for any installation costs associated with the replacement of this product. Your statutory rights are not affected. Déluce Lighting reserves the right to alter specifications without prior notice.



PLEASE READ THESE INSTRUCTIONS CAREFULLY BEFORE INSTALLATION
LEAVE A COPY FOR THE USER/MAINTENANCE ENGINEER FOR FUTURE REFERENCE
We recommend this fitting is installed by a qualified Electrician.

LED 1W EMERGENCY DOWNLIGHT FITTING INSTRUCTIONS

These instructions are for the Déluce Lighting 1W LED Emergency Downlight :

DLDP1WNMLED

Commissioning (Emergency luminaires)

Follow the procedure below to establish that the luminaire is working as it should:

- The battery should be connected to the luminaire via the flying plug and socket.
- Turn on the normal lighting supply (if a switched live supply is present), the lamp should light.
- Restore the mains supply and leave the luminaire to fully charge the battery, this will normally be complete in at most 24 hours. It is nevertheless advisable, to allow an initial charge of 48 hours before putting the batteries into service for the first time.

The date that this is carried out, must be marked in the space provided on the battery label.

PERIODIC TESTING (EMERGENCY LUMINAIRES) (Consult BS 5266-1:1999 for full details)

The luminaire must be checked periodically for correct operation, and to evaluate the remaining capacity in the battery at regular intervals during its life. Functional testing is facilitated by wiring a key operated control in series with permanent live supply to all the emergency luminaires in one area, operating this control fails the supply and places the luminaires wired to it into the emergency mode, so that they can be inspected.

- The luminaire should be fully functionally tested once a month.
- The luminaire should be tested in the emergency mode for at least one third of its rated duration every six months.
- After three years, and annually thereafter, the luminaire should be tested to ensure it achieves its entire rated duration of emergency operation.
- Record the periodic testing in the table below, and keep all records in a safe place.

IF THE LUMINAIRE FAILS TO ACHIEVE ITS RATED DURATION, THE BATTERY MUST BE REPLACED WITH A ONE, OF AN IDENTICAL TYPE, SEE THE LABEL ON THE BATTERY FOR THE ORDER REFERENCE.

LUMINAIRE LOCATION :				LUMINAIRE TYPE :		INSTALLATION DATE :	
MONTH	TEST Func: 1Hr / 3Hr	Year : _____ Sign & Date :	Year : _____ Sign & Date :	Year : _____ Sign & Date :	Year : _____ Sign & Date :	Year : _____ Sign & Date :	Year : _____ Sign & Date :
JAN							
FEB							
MARCH							
APRIL							
MAY							
JUNE							
JULY							
AUG							
SEPT							
OCT							
NOV							
DEC							



PLEASE READ THESE INSTRUCTIONS CAREFULLY BEFORE INSTALLATION
LEAVE A COPY FOR THE USER/MAINTENANCE ENGINEER FOR FUTURE REFERENCE
We recommend this fitting is installed by a qualified Electrician.