

# Disabled Persons Toilet Alarm Kit



<b>Quick start installation guide</b> .....	<b>2</b>
About this document .....	3
Important notes .....	3
Kit contents .....	4
Designing a disabled persons toilet alarm system .....	5
Installing the system (mains & extra low voltage wiring) .....	6
Engineer selectable functions .....	7/8
Basic operation .....	9
Expanding the system .....	10
Other 800 Series applications .....	11
Technical specifications .....	12

## DESIGN & INSTALLATION GUIDE

# QUICK START INSTALLATION GUIDE

The diagram below summarises key information provided in the rest of this document. For experienced installers, this should be all you need to get started. **If in doubt - or if using this equipment for the first time - read the full instructions.** All wiring should be provided in accordance with the current edition of the IEE Wiring Regs (BS 7671) and/or other national wiring rules as applicable.

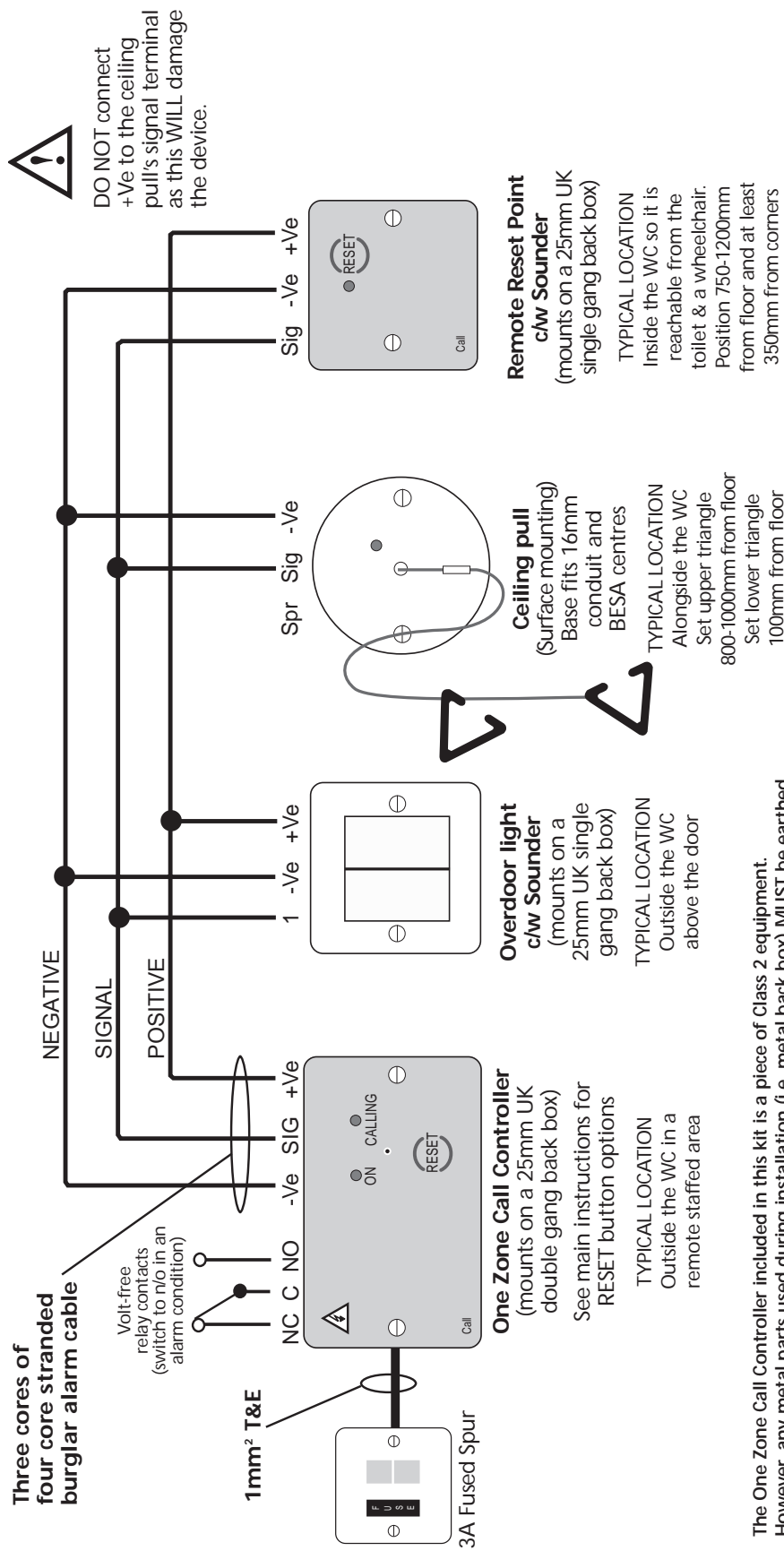

The One Zone Call Controller included in this kit is a piece of Class 2 equipment. However, any metal parts used during installation (i.e. metal back box) **MUST** be earthed. The earth termination point on the One Zone Call Controller is provided for installer convenience only and, as such, should only be used if an earth connection is not required elsewhere.

## ABOUT THIS DOCUMENT

This document provides a brief overview of disabled persons toilet alarm system design and installation, based on the recommendations of BS8300 (the code of practice for the design of buildings and their approaches to meet the needs of disabled people).

For further information, please refer to the full version of BS8300, copies of which are available at your local reference library or can be purchased from the BSI (British Standards Institute; Tel. +44 (0)20 8996 9000; Web: [www.bsi-global.com](http://www.bsi-global.com)). Other National standards of design and installation should be referenced and adhered to where applicable.

This document must not be left accessible to the user. A separate user guide (document no. DNU9510000) is available for this purpose.

No responsibility can be accepted by the manufacturer or distributors of this equipment for any misinterpretation of an instruction or guidance note or for the compliance of the system as a whole.

### IMPORTANT NOTES

This equipment must be installed and maintained by a suitably skilled and technically competent person.



The One Zone Call Controller included in this kit is a piece of Class 2 equipment. However, any metal parts used during installation (i.e. metal back box) **MUST** be earthed. The earth termination point on the One Zone Call Controller is provided for installer convenience only and, as such, should only be used if an earth connection is not required elsewhere.



This product has been manufactured in conformance with the requirements of all applicable EU Council Directives.

# KIT CONTENTS

This kit includes everything you need to create a high quality BS8300 clause compliant emergency assistance alarm, except cables and fixings. Dependent on the model purchased, the following items are included in the kit box:-

**NC809DBB Remote Reset Point c/w Sounder**

Includes a Braille label, reset button, red reassurance LED and on-board sounder.

**NC807C Ceiling Pull**

Includes a red reassurance LED, three metres of red pull cord and two triangular pull bangles.



**Accessory pack**  
Containing six device mounting screws and two shorting links.

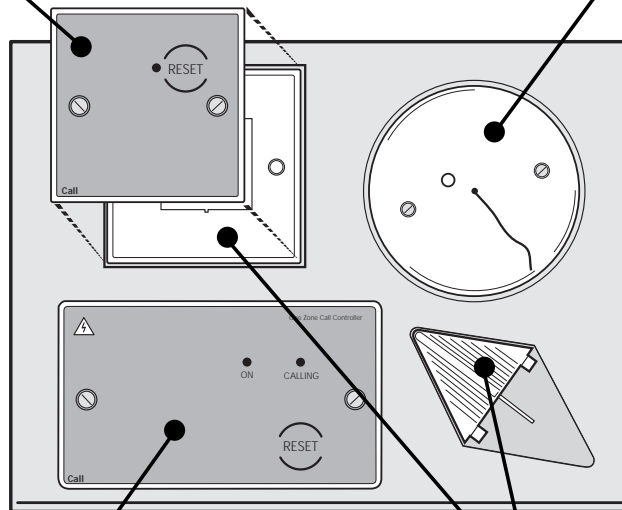

**NC949 Disabled WC Sticker**

A gloss finished, permanent vinyl sticker featuring the universally recognisable Disabled WC symbol.

**NC942 One Zone Call Controller**

(supplied in NC951 Standard Kits only)  
Includes an on-board 12V 140mA PSU, Braille label, alarm LED, power on LED, volume adjustable sounder, volt-free relay output and a link selectable reset/mute button.

or

**NC942B One Zone Call Controller**

(supplied in NC951B Elite Kits only)  
As per the NC942 but with an additional on-board rechargeable battery backup facility.

**NC806CS Overdoor Light c/w Sounder**

Comprises a triangular diffuser (containing two ultra-bright LEDs and a sounder) and a single gang mounting plate. Attach the diffuser to the mounting plate as shown below.

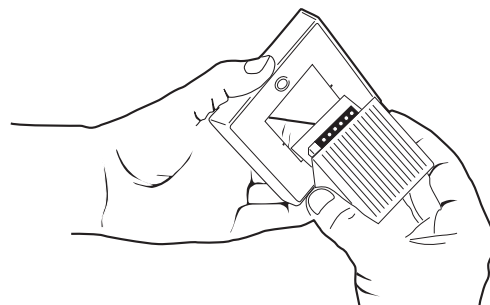

**Documentation**

Including a Design & Installation Guide (this document) and a User Guide.

## DESIGNING A SYSTEM

The diagram below shows a typical layout for a good practice disabled persons toilet alarm system based on the recommendations of BS8300. It should be noted that the exact position of the devices shown can be varied to suit a particular application provided that the recommendations described are met.

Other/alternative standards of design and installation should be adhered to where pertinent.

**Figure 2 : A Typical BS8300 Clause Compliant Emergency Assistance Alarm**

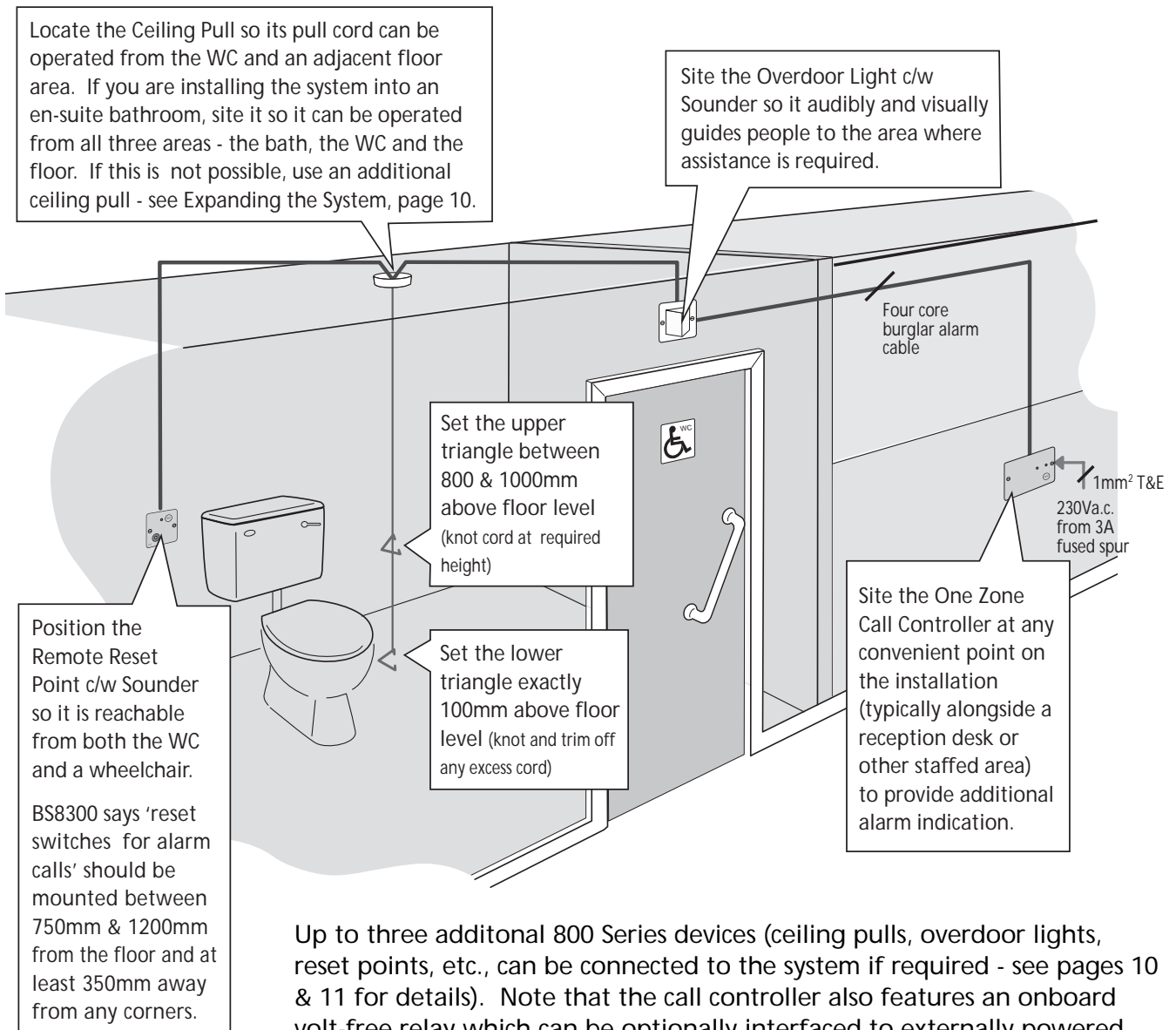

Up to three additional 800 Series devices (ceiling pulls, overdoor lights, reset points, etc., can be connected to the system if required - see pages 10 & 11 for details). Note that the call controller also features an onboard volt-free relay which can be optionally interfaced to externally powered beacons, strobes or other ancillary devices (again, see page 10 for details).

All system components should be sited internally in areas where they are readily accessible by the person(s) designated to use them. Areas should be clean and dry and the ambient light and sound levels should allow the status of all device indicators and sounders to be seen and heard. Any likelihood of tampering or vandalism should also be taken into account.

# INSTALLING THE SYSTEM

ALWAYS ENSURE THE MAINS SUPPLY IS ISOLATED BEFORE MAKING ANY CONNECTIONS.

**Figure 3 : Typical NC951/NC951B Disabled Persons Toilet Alarm Kit Wiring**

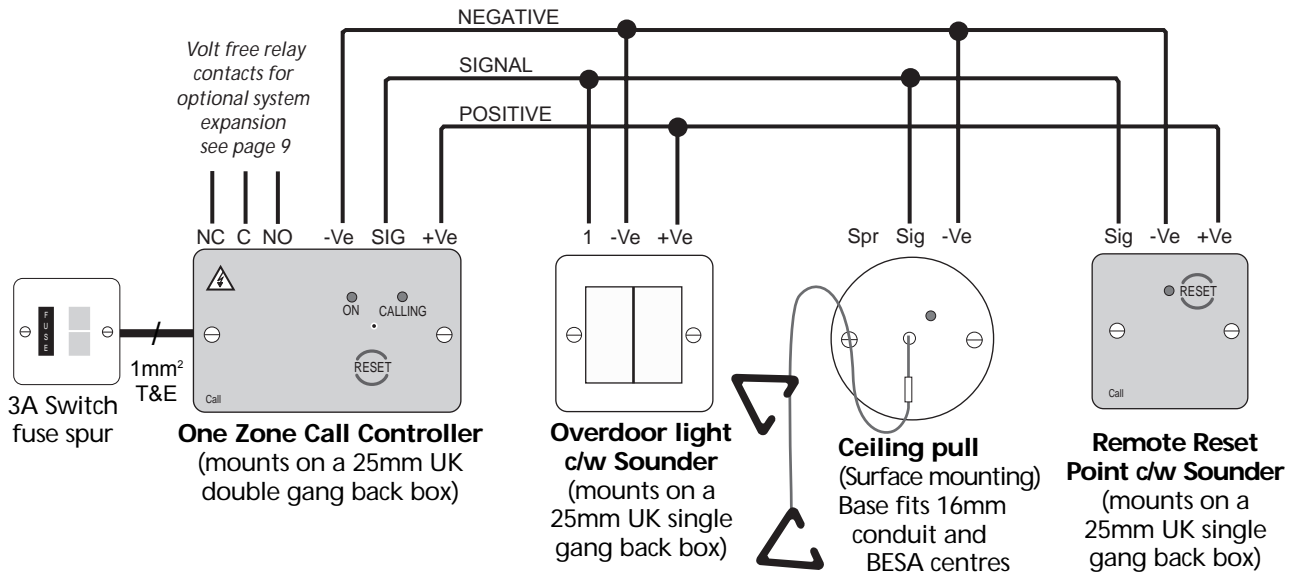

## Mains wiring

The general requirement for the mains supply to the call controller is fixed wiring, using three core cable of not less than 1mm<sup>2</sup>. This should be fed from an isolating switched fused spur, fused at 3A, which is marked appropriately and secure from unauthorised operation.

Live and neutral should be connected to the controller's L and N terminals respectively. If a plastic back box is used, make the earth connection to the terminal marked  $\perp$  at connector block CONN2. If a metal back box is used, the earth connection must be made to the earth bonding point on the back box.

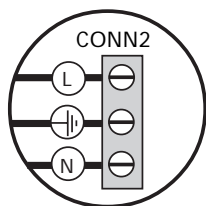

All external wiring brought into the unit must be adequately insulated with PVC or Neoprene.

All mains wiring should be provided in accordance with the current edition of the IEE Wiring Regs (BS 7671) or in accordance with the relevant national wiring rules.

## Extra low voltage (ELV) wiring

All low voltage wiring must be carefully planned before starting the job. Always segregate low voltage wiring from the mains wiring.

Three cores of four core stranded burglar alarm cable is ideal for most installations with all components requiring a positive, negative and signal connection (except the ceiling pull which DOES NOT require a positive connection).



**IMPORTANT:** Connecting positive to the ceiling pull's signal (Sig) terminal WILL permanently damage the device.

Note that the running order of the overdoor light, ceiling pull and reset point can be changed to suit a specific application and/or to reduce wiring runs.

All wall-mounting devices should be mounted onto a back box of the required depth. Assess the condition and construction of all mounting surfaces prior to installation and use a suitable screw fixing arrangement. Note that the ceiling pull is surface mountable.

**Important:** In the event of a short circuit on the low voltage wiring, an internal self-resetting fuse will temporarily isolate the system until the fault is cleared. The Call Controller is also protected by a non-serviceable thermal fuse in its transformer winding which will blow if there is a serious malfunction. If this happens, return the controller for repair.

# ENGINEER SELECTABLE FUNCTIONS

The NC942/NC942B One Zone Call Controller has a number of engineer selectable functions. This section of the manual explains how these functions work and how to implement them.

**Figure 4 : Rear view of the NC942/NC942B One Zone Call Controller**

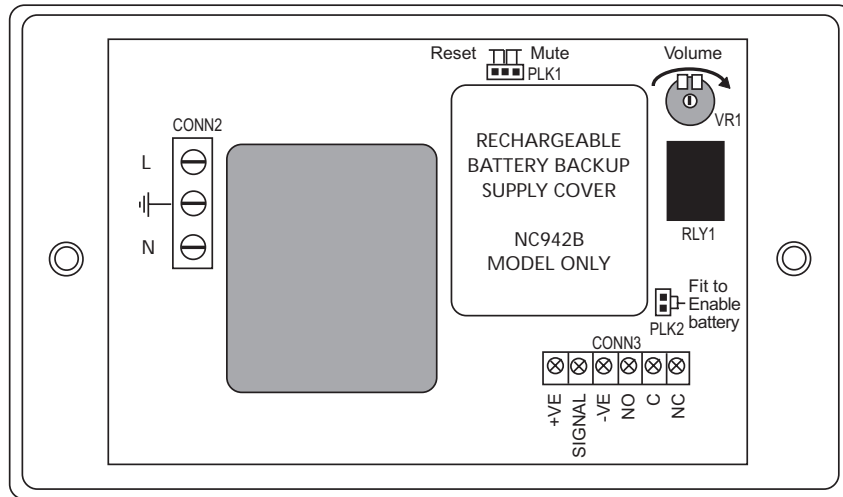

## Reset button operation (Link PLK1)

Link PLK1 allows the call controller's on-board RESET button to be set up to:-

### (a) Reset the system

In this position, pressing the controller's RESET button when an alarm signal is active will return the entire system to its normal state.



### (b) Mute the system

In this position, pressing the controller's RESET button when an alarm signal is active will mute the controller's on-board sounder. All other sounders and reassurance LEDs will remain active until the Remote Reset Point's RESET button is pressed inside the WC.



### (c) Have no effect

In this position (no link fitted), pressing the controller's RESET button when an alarm signal is active will have no effect.

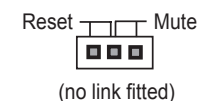

**WARNING:** Many authorities insist that the reset function of a call system be carried out at 'point of source' (i.e. in the room in which the call was made) to ensure that the person who raised the alarm is visited. Therefore, unless there is a definite requirement to the contrary, we recommended you choose option (c) above. If in doubt, speak to the building manager for advice. Note that the default setting for Link PLK1 is link not fitted/no effect and that the shorting link is provided in the kit's accessory pack.

## Volume control (Potentiometer VR1)

Potentiometer VR1 can be used to adjust the level of the call controller's on-board sounder. The default setting for the volume control is its mid-setting. Turning the control clockwise with a terminal screwdriver will increase the volume, turning it anti-clockwise will decrease it. The actual level required will normally depend upon the ambient noise levels within the building and personal preference.

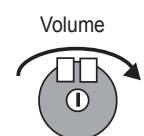

## On-board volt-free relay operation (RLY1)

The call controller includes an on-board volt-free relay with normally open (NO), normally closed (NC) and common (C) contacts. The relay contacts are rated at 30Vd.c. @ 1A and can be used to switch optional externally powered devices such as sounders, strobes or the extra low voltage coils of mains controlling relays.

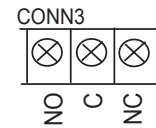

When no calls are on the system, the normally closed contact is made. When an alarm signal is present, the relay switches and the normally open contact is made. Muting the system will have no effect on the relay's operation.

See EXPANDING THE SYSTEM, page 9, for typical wiring schematics.

## Battery backup enable/disable (Link PLK2) Available on NC942B controllers only

Link PLK2 enables or disables the call controller's 500mAHr rechargeable battery backup facility. Note that this facility is available on NC942B call controllers only. NC942B controllers are supplied as standard in our NC951B Elite Kits and are distinguishable by the white plastic enclosure on their reverse.



When enabled (link PLK2 fitted), the NC942B's onboard battery backup supply will continue to power the system for approximately 24 hours (standby) plus 15 minutes (alarm running time) in the event of a mains failure. This will be indicated by the controller's 'ON' LED flashing green approximately once per second.

Should the mains supply remain disconnected for a prolonged period of time, the battery backup facility will automatically shutdown to prevent the batteries from deep discharge.

Note that the default setting for Link PLK2 is link not fitted/battery disabled. This is to conserve battery life and ensure the safety of the controller during storage/transit. Note that the shorting link required to enable the facility is provided in the kit's accessory pack.

## Optional emergency/distress call level (Extra equipment required)

If required, the call controller can be used to generate an additional, more urgent level of call using separately available components from our 800 Series Call System range. Compatible devices include the NC804DE emergency call point and the NC802DEWM water resistant alert point (see pages 9 & 10 for details). These devices are typically used to allow the person attending to the call to request additional assistance should the person who raised the alarm be in distress.

When an emergency/distress call is triggered, an active or muted standard alarm call will be overridden. The controller's 'CALLING' LED will flash red and its on-board sounder (and relay) will pulse intermittently. The overdoor light c/w sounder outside the WC will also pulse to indicate that more urgent assistance is required.

Up to three additional calling devices can be connected to an NC942 or NC942B call controller. Should you wish to connect more, consider using an NC941 call controller which is specifically designed for powering larger single zone call systems. Information on how to connect additional devices to the system can be found on page 9.

## Sounder and LED test facility

Pressing the controller's RESET button when link PLK1 is fitted in the Reset (a) position will cause all of the system's sounders and LEDs (apart from the ceiling pull's LED) to activate. When the button is released, the LEDs and sounders will switch off. The same test can be carried out by pressing the Remote Reset Point's RESET button.



## BASIC OPERATION

Once the system has been installed, check that it works correctly with reference to the diagrams below.

### Raising an alarm

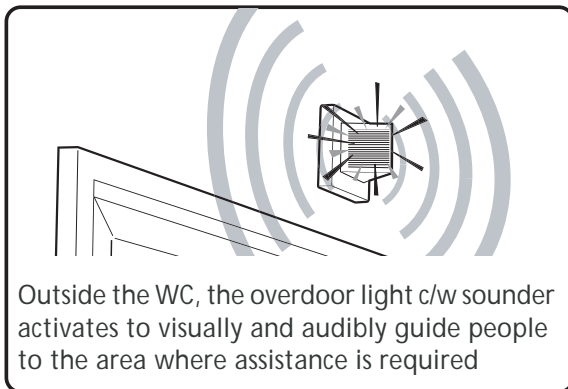
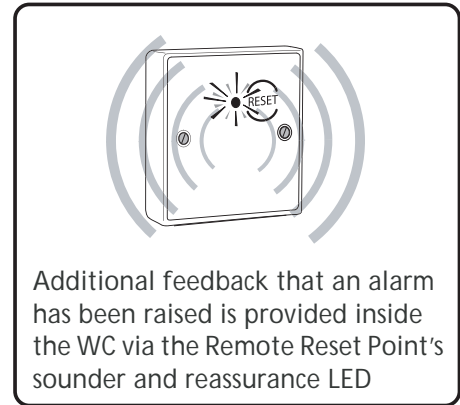
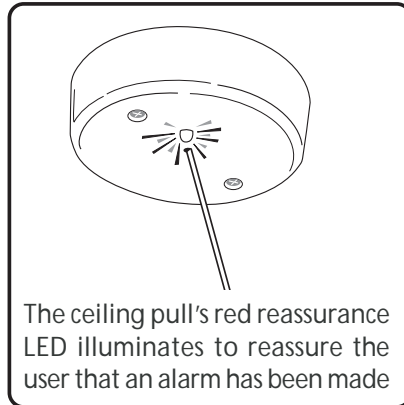
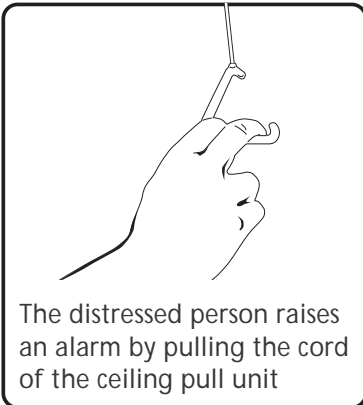

Note that the call controller's onboard relay will also activate when an alarm call is made and any external equipment connected to the controller's relay contacts will operate as configured.

### Resetting the system

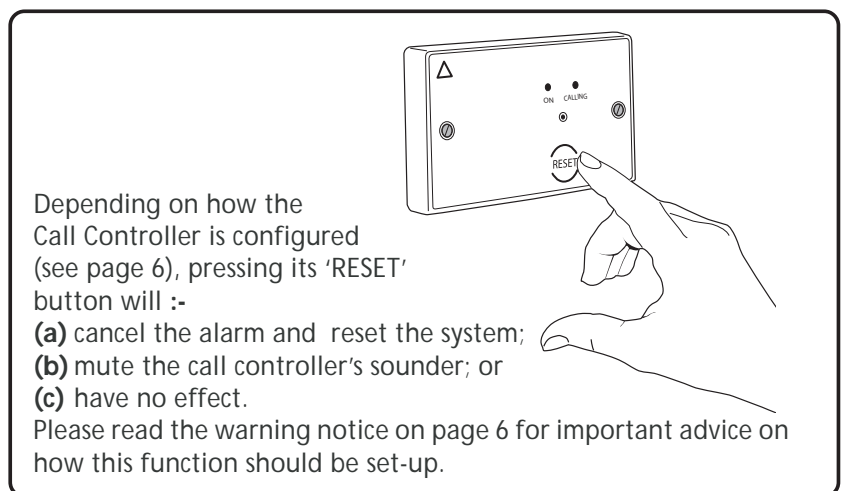
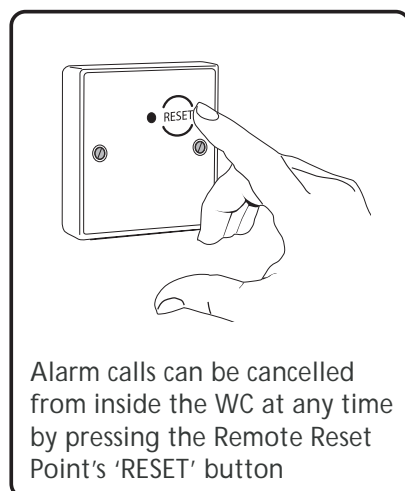

## EXPANDING THE SYSTEM

The diagrams below show how the system can be optionally expanded to suit a particular application.

### Connecting additional 800 Series devices to the system

Up to three additional 800 Series devices (any mix) can be connected to the system as shown below. Should you wish to connect more than three devices, consider using an NC941 call controller which is specifically designed for use on more heavily populated single zone systems. Devices can be wired to the call controller in any order to suit the application.

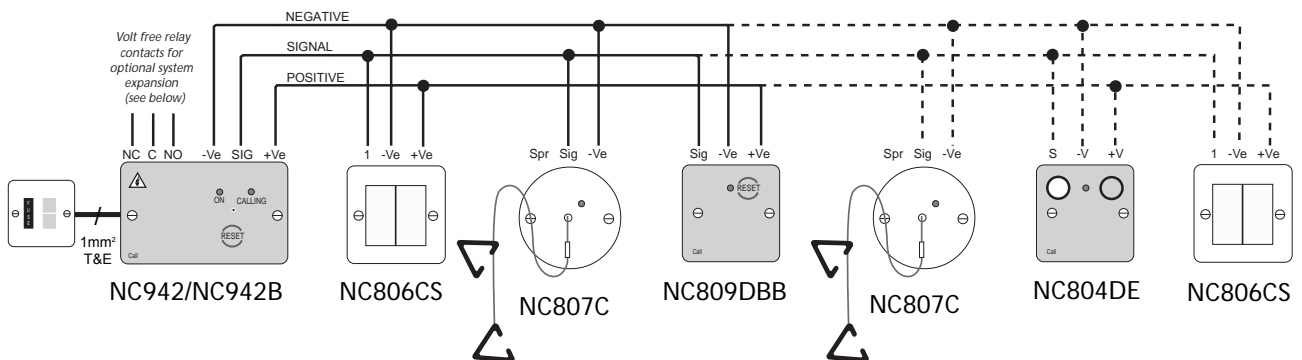

### Connecting a non-800 Series device to the system via the controller's relay output

The call controller's volt-free relay contacts are rated at 30Vd.c. @ 1A and can be used to switch optional externally powered devices such as sounders, strobes or the extra low voltage coils of mains controlling relays. A typical wiring schematic appears below. When an alarm signal is present, the relay switches from normally closed to normally open.

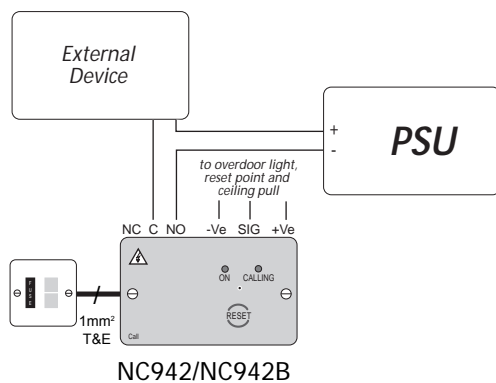

# OTHER 800 SERIES APPLICATIONS

800 Series Call Systems can be used for literally hundreds of applications ranging from simple one zone installations in disabled persons toilets to multi-zone systems in nursing homes, hotels, shops, council offices and GP surgeries. In addition to the items included in this kit, a wide range of additional components are available including multi-zone indicator panels, wall-mounting call points (in plastic and stainless steel), water resistant alert points, infrared ceiling receivers, monitoring points and remote sounders. The diagram below shows a small selection of the devices available - please contact your distributor for further details.

## LEISURE CENTRES & POOLS

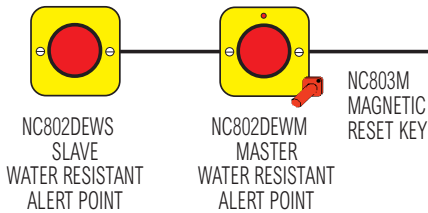

## MEETING & CONFERENCE ROOMS

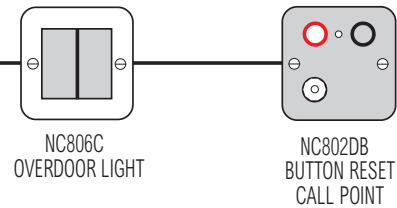

## CHANGING ROOMS

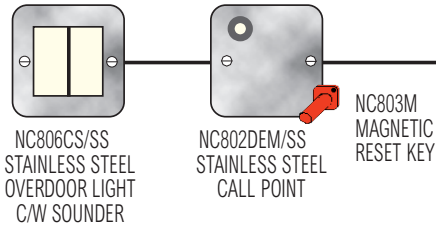

## INFRARED PANIC ATTACK SYSTEMS

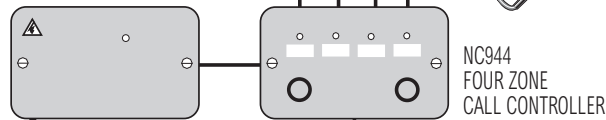
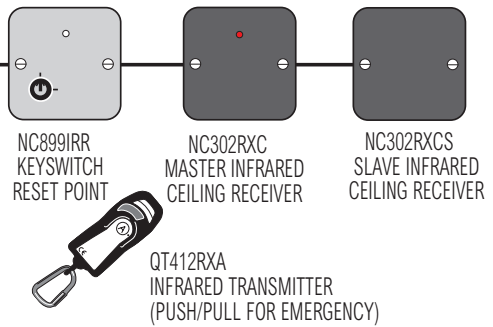

For 12 zone systems, use three four zone call controllers connected to one NC925B1 12V 1A white boxed PSU.

For larger systems (up to 90 zones in size), use our 'K' or 'KE' range of indicator panels.

## NURSING HOMES & HOSPITALS

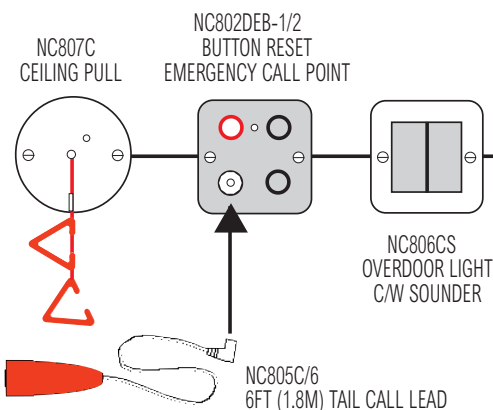

## DOOR MONITORING SYSTEMS

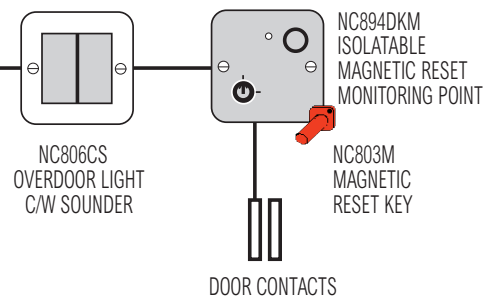

TO OTHER ZONES

— = Four core security cable

## TECHNICAL SPECIFICATIONS

### **NC942 One Zone Call Controller**

Mains supply: Voltage: 230V a.c.; Max current: 23mA; Frequency: 50Hz.  
Output: Voltage: 12V d.c.; Current: 140mA; Volt-free relay contacts (NO/C/NC).  
Indicators: Red alarm present LED; Green supply present LED.  
Sounder: Active in alarm.  
Controls: 'RESET' Button (link selectable for reset, mute or no function).  
IP Rating: IP31 when correctly installed.  
Dimensions: 147 x 87 x 39mm (WxHxD). Mounts on 25mm UK double gang back box.

### **NC942B One Zone Call Controller with battery backup facility**

Mains supply: Voltage: 230V a.c.; Max current: 23mA; Frequency: 50Hz.  
Output: Voltage: 12V d.c.; Current: 140mA; Volt-free relay contacts (NO/C/NC).  
Indicators: Red alarm present LED; Green supply present LED (flashes green when battery back up is active in the event of mains failure).  
Controls: 'RESET' Button (link selectable for reset, mute or no function).  
IP Rating: IP31 when correctly installed.  
Dimensions: 147 x 87 x 39mm (WxHxD). Mounts on 25mm UK double gang back box.

### **NC807C Ceiling Pull**

Input: Voltage: 12V d.c.; Connections: Signal and -Ve.  
Pull cord: Generates an alarm call when activated.  
Indicators: Red reassurance LED active in alarm.  
IP Rating: IP41 when correctly installed.  
Dimensions: 93mm diameter x 27mm deep. Surface mountable.

### **NC806CS Overdoor light c/w sounder**

Input: Voltage: 12V d.c.; Connections: Signal, -Ve and +Ve.  
Indicators: Dual ultra-bright red LEDs active in alarm.  
Sounder: Active in alarm.  
IP Rating: IP41 when correctly installed.  
Dimensions: 87 x 87 x 68mm (WxHxD). Mounts on 25mm UK single gang back box.

### **NC809DBB Reset point c/w sounder**

Input: Voltage: 12V d.c.; Connections: Signal, -Ve and +Ve.  
Indicators: Red reassurance LED active in alarm.  
Sounder: Active in alarm.  
IP Rating: IP41 when correctly installed.  
Dimensions: 87 x 87 x 24mm (WxHxD). Mounts on 25mm UK single gang back box.

# 800 SERIES

© 1996-2005. Approved Document No: DNU0951001 Rev 1. We reserve the right to alter product specifications at our discretion and without prior notice. Errors and omissions excepted. This manual has been carefully checked prior to publication. However, no responsibility can be accepted by the manufacturer or distributors of this equipment for any misinterpretation of an instruction or guidance note or for the compliance of the system as a whole.