

LED WALL PACKS

Photocell 40W 3000K



PHILIPS
DRIVER AS STANDARD

KEY DATA

Power	40W
Luminous Flux	3000lm
Colour Temperature	3000K
IP Rating	IP65
Dimensions	308x288x182mm
Warranty	5 Years Extended

Part Number

NET-11-11-31

TECHNICAL SPECIFICATIONS

Input Voltage	220-240V AC
Power Factor	>0.95
LED Luminous Flux	3600lm
Luminous Efficacy	>80lm/W
LED Manufacturer	Honglitronic
LED Type	SMD 2835
No. of LEDs	84
Driver Manufacturer	Philips
Driver Output Voltage DC	36-40
Total Circuit Power (W)	40+/-5%
Electrical Class	1
Colour Rendering	>80 CRI
Lamp Viewing Angle	125°
Dimmable	No
Operating Temp.	0 to +45°C
Lifespan	50,000 hours
Fire Rating	V-0
UGR Rating	22
Diffuser Material	Polycarbonate
Housing Material/Colour	Aluminium/Black
Weight	2.7kg

DIMENSIONS

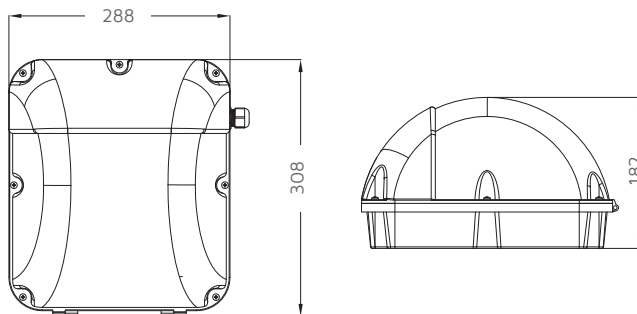

All units are in mm

LIGHT DISTRIBUTION CURVE

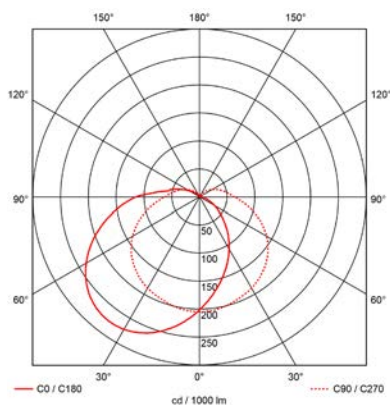

TYPICALLY REPLACES

- 70W SON

FEATURES & BENEFITS

- Weather, dust and vandal-proof IP65 rated housing.
- LED chips positioned strategically inside the unit for maximum distribution of light.

CE RoHS

IES Data Files available



Our Service

As part of your distribution chain, we recognise the importance of providing a quality, reliable service so that you are able to do the same for your customers.

We work with our strategic distribution partner UPS to provide a next working day delivery service for all orders placed before 5 p.m. (please allow up to 48 hours for Scotland, Northern Ireland and the Isle of Man).

Orders are picked and packed using hand-held laser barcode scanners, streamlining your processes and ours, allowing us to work through your orders with speed and accuracy.

Our full product range is listed in the Luckins Database. Products are available exclusively through UK national and independent wholesalers.

Our People

Our business is driven by a team of experienced sales, operations and customer service individuals. Our team is professional, knowledgeable and ready to fulfill your needs.

You have access to a Regional Sales Manager and Internal Sales Support team member. They work with you to take care of your business requirements and help you to help your customers.

Our technical support team is on-hand to answer your technical queries and provide data sheets, IES data files and lighting guides.

Our logistics and warehouse operations team is well-equipped and dedicated to despatching your orders accurately and efficiently to wherever they are needed, on time every time.

Your Choice

We want to make sure you provide your customers with quality commercial LED lighting products as and when they need them. Our service is tailored to work for you, and with many of our products covered by a 5 Year Extended Warranty, we want to give you the peace of mind you need when putting your trust in a supplier.

T: 01223 851505
F: 01223 851506
E: orders@netled.co.uk

NET LED Limited
Evolution Business Park
Milton Road
Impington
Cambridge
CB24 9NG

www.netled.co.uk

