

LED HIGH POWER FLOOD LIGHTS 200W 6000K



PHILIPS
DRIVER AS STANDARD

KEY DATA

Power	200W
Luminous Flux	16800lm
Colour Temperature	6000K
IP Rating	IP65
Dimensions	425x325x200mm
Warranty	5 Year Extended

Part Number

NET-15-04-15

TECHNICAL SPECIFICATIONS

Input Voltage	220-240V AC
Power Factor	>0.90
LED Luminous Flux	22000lm
Luminous Efficacy	>110lm/W
LED Manufacturer	Bridgelux
LED Type	45mil
LED Wattage	3x60W
Driver Manufacturer	Philips
Driver Output Voltage DC	36-48
Total Circuit Power (W)	185+/-5%
Electrical Class	1
Colour Rendering	>75 CRI
Lamp Viewing Angle	120°
Dimmable	No
Operating Temp.	-20 to +50°C
Lifespan	50,000 hours
UGR Rating	22
Diffuser Material	Glass
Housing Material/Colour	Aluminium/Colour
Weight	10.4kg

DIMENSIONS

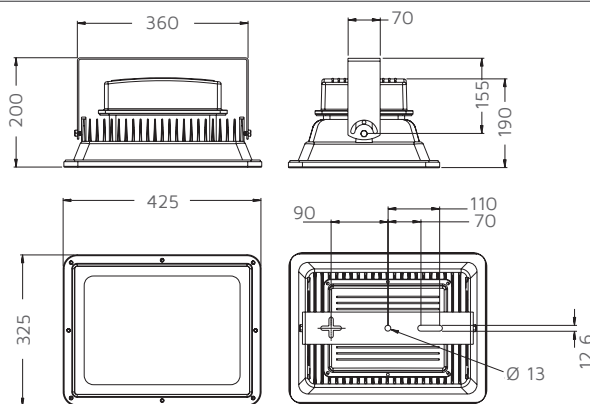

All units are in mm

LIGHT DISTRIBUTION CURVE

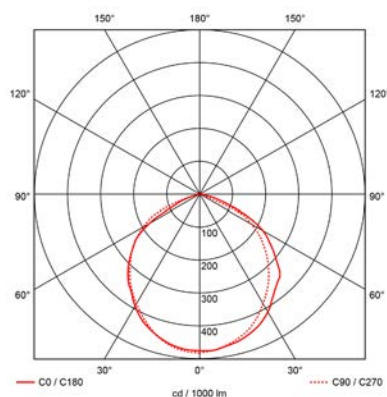

AVERAGE BEAM ANGLE: 120°

TYPICALLY REPLACES

- 400W metal halide
- 400W SON

FEATURES & BENEFITS

- IP65 rated housing.
- Shatterproof glass lens.
- Secure stirrup bracket for safe mounting.
- Housing colour grey only.
- 5 Year Extended Warranty.

CE RoHS

IES Data Files available



Our Service

As part of your distribution chain, we recognise the importance of providing a quality, reliable service so that you are able to do the same for your customers.

We work with our strategic distribution partner UPS to provide a next working day delivery service for all orders placed before 5 p.m. (please allow up to 48 hours for Scotland, Northern Ireland and the Isle of Man).

Orders are picked and packed using hand-held laser barcode scanners, streamlining your processes and ours, allowing us to work through your orders with speed and accuracy.

Our full product range is listed in the Luckins Database. Products are available exclusively through UK national and independent wholesalers.

Our People

Our business is driven by a team of experienced sales, operations and customer service individuals. Our team is professional, knowledgeable and ready to fulfill your needs.

You have access to a Regional Sales Manager and Internal Sales Support team member. They work with you to take care of your business requirements and help you to help your customers.

Our technical support team is on-hand to answer your technical queries and provide data sheets, IES data files and lighting guides.

Our logistics and warehouse operations team is well-equipped and dedicated to despatching your orders accurately and efficiently to wherever they are needed, on time every time.

Your Choice

We want to make sure you provide your customers with quality commercial LED lighting products as and when they need them. Our service is tailored to work for you, and with many of our products covered by a 5 Year Extended Warranty, we want to give you the peace of mind you need when putting your trust in a supplier.

T: 01223 851505
F: 01223 851506
E: orders@netled.co.uk

NET LED Limited
Evolution Business Park
Milton Road
Impington
Cambridge
CB24 9NG

www.netled.co.uk

